



READY MIX







# MORE THAN 50 YEARS OF INNOVATION AT THE SERVICE OF THE BUILDING INDUSTRY

More than 50 years in business have taught us that only by forging a firm link between the client's experience and dynamic design and manufacturing we can produce quality products that fully meet market demands.

The high level of know-how of our workforce ensures complete control of all processes, from design to the after-sales service.

That is why we are a reliable partner in the development of solutions for precast factories - before, during and after the sale.

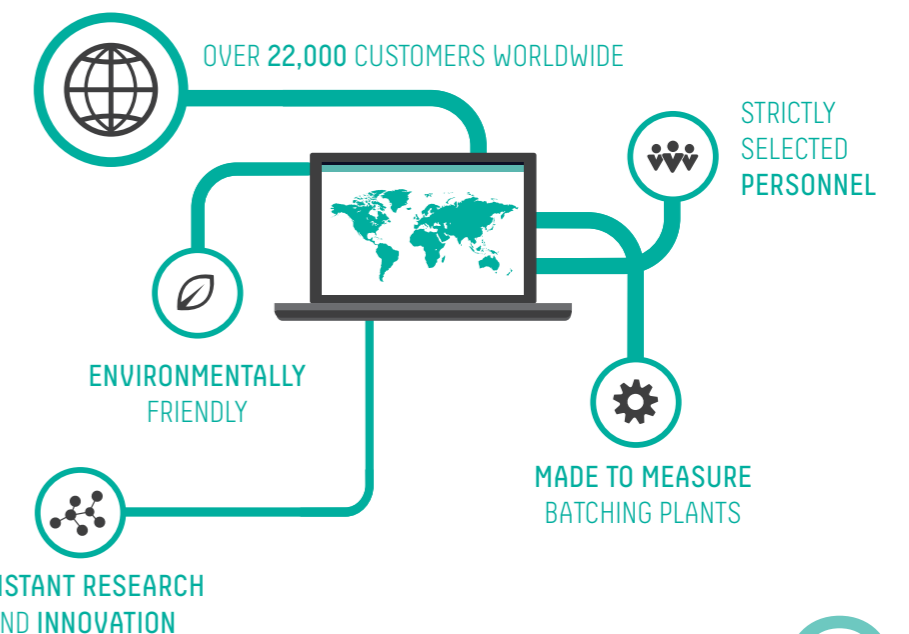



## READYMIX PRODUCT RANGE

A wide range of equipment for the production of ready-mix concrete for sale or for large-scale construction works. The concrete produced in our batching plants is capable of meeting the highest

quality standards even for special use and for high-performance structures. Total control in the formulation of the batching recipes and utmost mixing quality.



*Mobile Batching Plants*



*Stationary batching plants*



*Mixers*



*Management system*



## MOBILE BATCHING PLANTS



MOBILE

# ORUMULTIS

The ORU MULTIS range is the new line of mobile batching plants of IMER GROUP with a production capacity from 30 up to 65 m<sup>3</sup>/h. All the ORU MULTIS configurations are completely pre-wired and pre-assembled.



## PRODUCT RANGE

ORUMULTIS 30

ORUMULTIS 50

ORUMULTIS 55

ORUMULTIS 65

MIXING SYSTEM WITH  
PLANETARY MIXERS ORU MS

EASIER TRANSPORTABILITY

EXTREME MOBILITY

UTMOST RELIABILITY



## SAUDI ARABIA

*ORU MULTIS 55 with LOGIK WL4 storage unit equipped with ORU MS 1500/1000A planetary mixer. Ideal for ready-mixed concrete production for construction.*

# GENERAL LAYOUT

## ORUMULTIS 50\_55\_65L WITH BELTUP

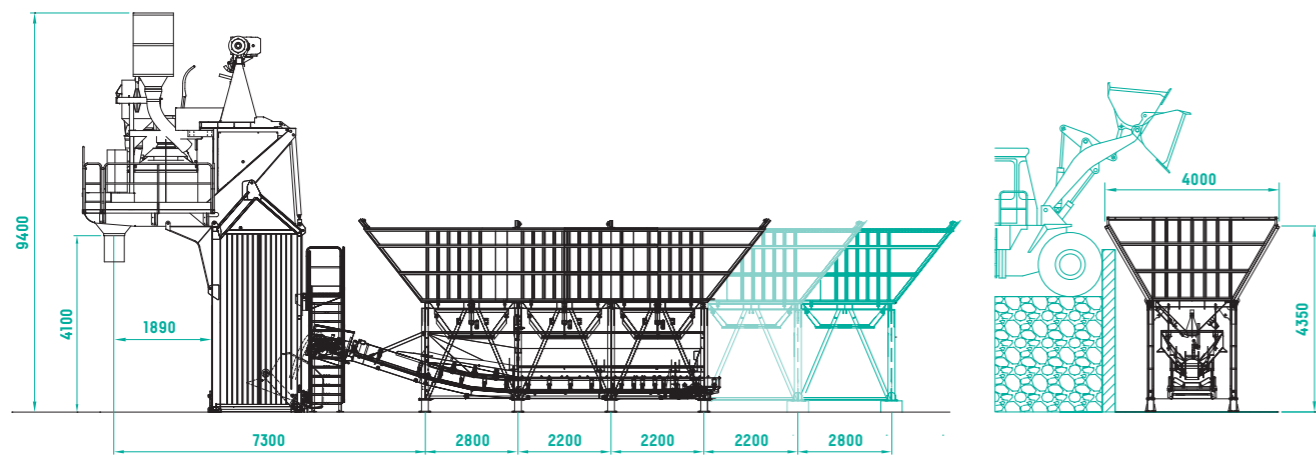

## ORUMULTIS 30L WITH STRAIGHT BELT

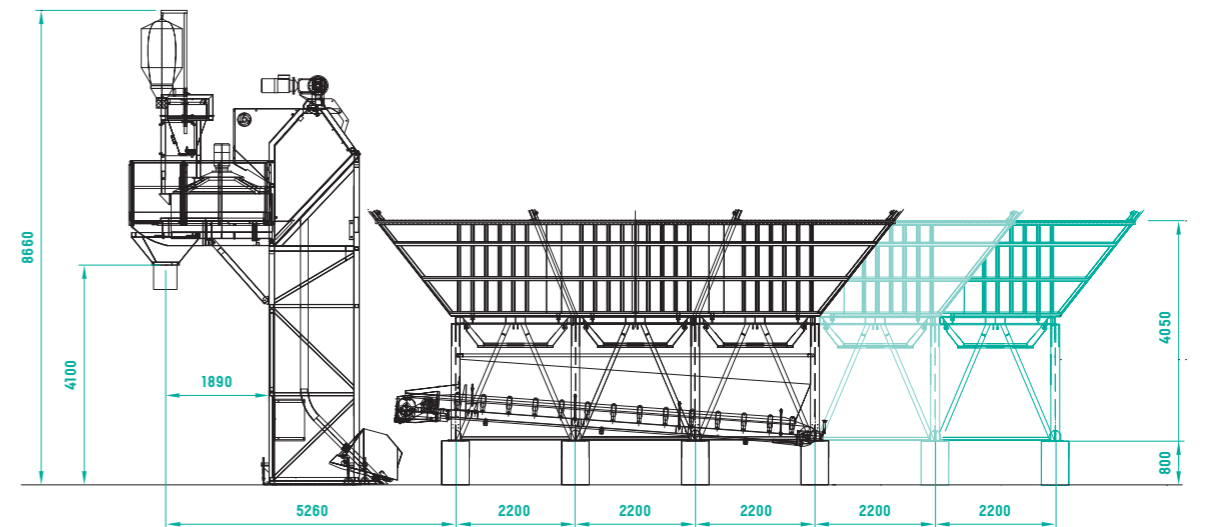

## ORUMULTIS 30S WITH BELTUP

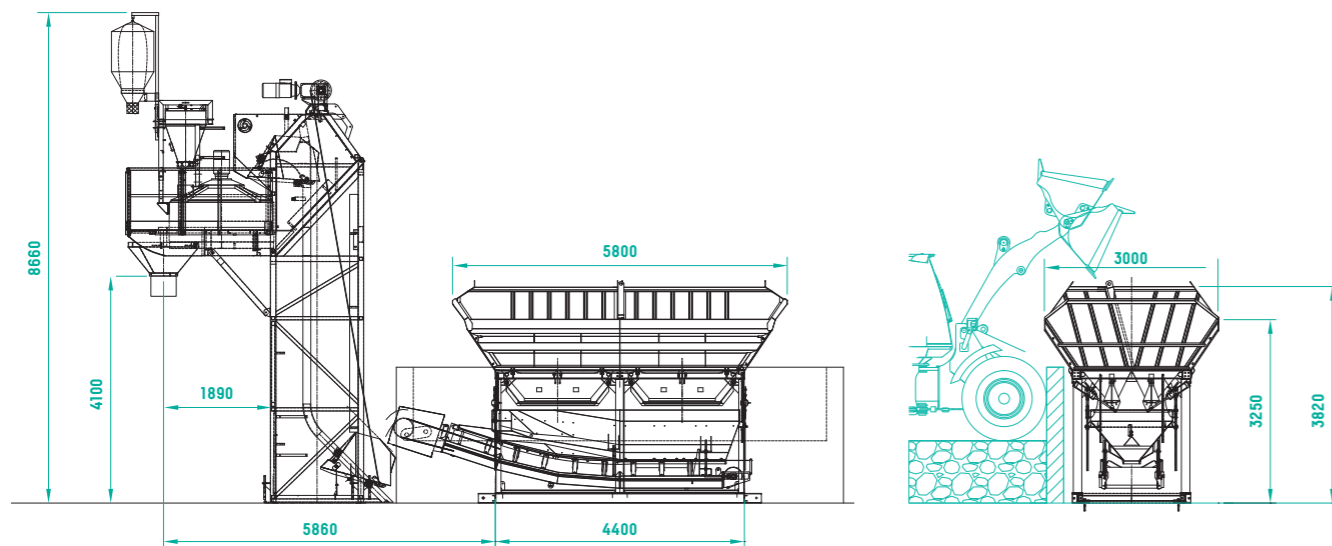

## ORUMULTIS 50\_55\_65B WITH BELTUP

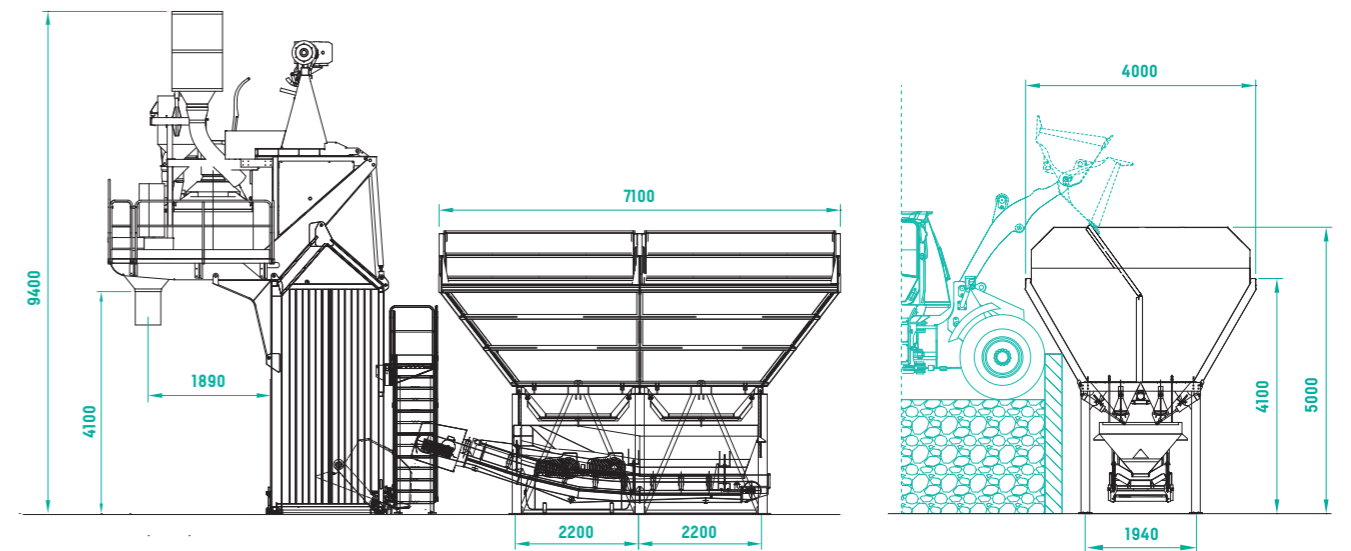



**FRENCH GUIANA**

*ORU MULTIS 65 with ORU CUBE B storage unit equipped with ORU MS 1875/1250A planetary mixer. Ideal for ready-mixed concrete production for construction.*

## EASY TO TRANSPORT AND FAST TO INSTALL

PRE-WIRING - To meet the requirements of speed, versatility and compactness, ORU MULTIS is entirely pre-wired. This operational solution significantly reduces the installation and commissioning time of the batching plant.



### TRANSPORTABLE AND PRE-ASSEMBLED

30S - 30B



**BY ROAD**  
2 STANDARD TRUCKS (13.6 M)



**BY SEA**  
2X40' OT  
+ 1X20' OT H=2450

30L



**BY ROAD**  
2 STANDARD TRUCKS (13.6 M)



**BY SEA**  
2X40' OT

50-55-65B



**BY ROAD**  
2 STANDARD TRUCKS (13.6 M)



**BY SEA**  
1X40' OT  
+ 1X40' OT H=2450

50-55-65L



**BY ROAD**  
2 STANDARD TRUCKS (13.6 M)  
+ 6 M OF TRUCK



**BY SEA**  
2X40' OT + 1X40' OT  
H=2450

*Transport valid for the standard configuration.*



## DISTINCTIVE FEATURES



- MIXING UNIT WITH PLANETARY MIXER: PERFECT MIXING AND EXCELLENT CLEANING
- PRE-ASSEMBLED AND PRE-WIRED MONOBLOCK THAT SIGNIFICANTLY REDUCES INSTALLATION AND START-UP TIME
- EXTREME MOBILITY AND TRANSPORTABILITY
- EASY INSTALLATION THANKS TO MINIMAL FOUNDATION NEEDS
- SIMPLE TO USE

*ORU MULTIS 50\_55\_65 mixing unit with built-in skip and cabin even during transport phases*

## EASY AND FAST TO INSTALL



## FLASH SOLUTION FOR BATCHING

### BELTUP

#### WEIGHING BELTS

- NO CONCRETE PILLARS AND/OR SKIP PIT
- LOW AGGREGATE LOADING POINT WITHOUT REDUCING CAPACITY

#### MOBILE FOUNDATIONS

- EASY AND FAST
- REALLY MOBILE



### VF MOBILE RAMPS

- MAXIMUM TRANSPORTABILITY
- QUICK INSTALLATION
- NO CONCRETE FOUNDATIONS



## DIFFERENT LOADING SYSTEMS

### LOADING

#### BY PAYLOADER



### LOADING

#### BY RADIUS LIFT ARM





## AGGREGATES STORAGE UNITS

The **ORU MULTIS** batching plants can be equipped with different types of aggregates storage units for the utmost versatility and adaptability:

### ORU CUBE

(CUBE S and CUBE B with 2 bins for 3 or 4 aggregates)

### ORU LOGIK

(LOGIK L with 3-4 or 5 bins)

### SOUTH AFRICA

**ORU MULTIS 30 with CUBE S equipped with ORU MS 750/500 planetary mixer.**

**Ideal for ready-mixed concrete production for construction in agile and low environmental impact sites.**

### TECHNICAL CHARACTERISTICS - (Standard configuration)

		ORUMULTIS 30L	ORUMULTIS 30S	ORUMULTIS 30B	ORUMULTIS 50L	ORUMULTIS 55L	ORUMULTIS 65L	ORUMULTIS 50B	ORUMULTIS 55B	ORUMULTIS 65B
Hourly production	m <sup>3</sup> /h	30	30	30	50	55	65	50	55	65
Batch capacity (vibrated concrete)	m <sup>3</sup>	0,5	0,5	0,5	0,8	1,0	1,25	0,8	1,0	1,25
Power required	kW	40	40	40	43	68	76	43	68	76
Planetary mixer	mod	ORUMS 750/500	ORUMS 750/500	ORUMS 750/500	ORUMS 1200/800	ORUMS 1500/1000A	ORUMS 1875/1250A	ORUMS 1200/800	ORUMS 1500/1000A	ORUMS 1875/1250A
Skip (speed)	m/s	0,39	0,39	0,39	0,50/0,55	0,50/0,55	0,50/0,55	0,50/0,55	0,50/0,55	0,50/0,55
Cement weighing hopper	l	230	230	230	655	655	655	655	655	655
Water system with electromagnetic meter and pump	Ø	DN40	DN40	DN40	-	-	-	-	-	-
Water weighing hopper	l	250 (optional)	250 (optional)	250 (optional)	400	400	400	400	400	400
Aggregates storage (capacity)	m <sup>3</sup>	65+210	20	54+110	65+210	65+210	65+210	54+110	54+110	54+110
Weighing system (type-approved)	mod	with loading cells	with loading cells	with loading cells	with loading cells	with loading cells	with loading cells	with loading cells	with loading cells	with loading cells
Aggregates hygrometer probe (microwave) (recommended optional)	mod	PK-3	PK-3	PK-3	PK-3	PK-3	PK-3	PK-3	PK-3	PK-3
Additives system (recommended optional)	l/min	13	13	13	13	13	40	13	13	40
Electric compressor (recommended optional)	mod	B6000	B6000	B6000	B6000	B6000	B6000	B6000	B6000	B6000
Management unit (recommended version)	mod	HPS 2100V	HPS 2100V	HPS 2100V	HPS 2100V	HPS 2100V	HPS 2100V	HPS 2100V	HPS 2100V	HPS 2100V



*MOBILE WET*

# ORUDAY

The ORUDAY batching plants are pre-assembled and pre-wired and allow easy transportability by normal transport means.

They are designed to reduce the time and space needed for the installation in the worksite. The mixing process takes place in planetary mixers or twin shaft mixers depending on the model.

The range includes models with production capacities from 60 to 150 m<sup>3</sup>/h.

The ORUDAY batching plants can be equipped with different types of aggregates storage units, for maximum versatility and adaptability.



**QATAR**

*ORU DAY 125B with LOGIK WB4 storage unit equipped with ORU MD 4500/3000 horizontal twin shaft mixer. Ideal for ready-mixed concrete production for construction and structural works in sites that must guarantee high performance.*



MIXING SYSTEMS  
WITH PLANETARY MIXERS ORU MS  
OR TWIN SHAFT MIXERS ORU MD

MAXIMUM TRANSPORTABILITY

MAXIMUM COMPACTNESS

MAXIMUM RELIABILITY

**PRODUCT RANGE**

ORUDAY 70

ORUDAY 100

ORUDAY 110

ORUDAY 125

ORUDAY 130

ORUDAY 150D

## ORU DAY MS MIXING UNIT

The mixing unit is composed of:

A frame made of **heavy-duty steel beams** which, together with the rails for the skip, the electrical panel cabin, the mixer and the water and cement weighing hoppers form a **single bloc**.

The **skip** with a particular geometric shape is fitted with deflectors that allow a large area for loading the aggregates. These **deflectors** close when the skip rises thus preventing the material from falling out. **Unloading** takes place in the lower part of the skip through a simple tilting hatch: during this stage the skip is in the vertical position, allowing quick and complete unloading also in the presence of compact and wet materials without leaving remains inside.

The **cement weighing hopper** and the **water weighing hopper** rest on a support structure hinged to the front part of the mixing unit.

- MIXING UNIT WITH PLANETARY MIXER FOR PERFECT MIXING AND EXCELLENT CLEANING
- PRE-ASSEMBLED AND PRE-WIRED MONOBLOCK THAT SIGNIFICANTLY REDUCES INSTALLATION AND START-UP TIME
- EXTREME MOBILITY AND TRANSPORTABILITY
- EASY INSTALLATION THANKS TO MINIMAL FOUNDATION NEEDS
- SIMPLE TO USE

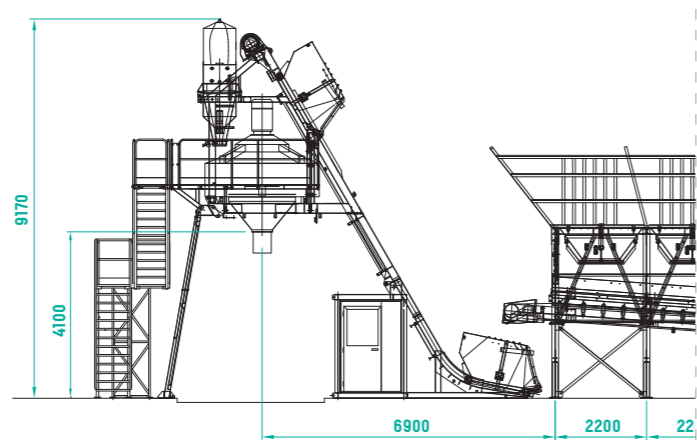

ORUDAY mixing unit with built-in skip and cabin even during transport phases

## ORU DAY MD MIXING UNIT

The mixing unit is composed of:

A **frame** made with a patented **hinge** system that allows a fast and safe installation on the worksite, and together with the rails for the **skip**, the electrical panel **cabin**, the **mixer** and the **water and cement weighing hoppers** forms a **single bloc**.

The **skip** is composed of a truncated pyramid-shape hopper which is very stiff and is able to carry also very large-size aggregates. The **lifting system** is extremely reliable thanks to the winch with double cable and the additional automatic winding control.

A timed electronic device checks all the phases in order to ensure the **maximum safety**. The ascent and descent **speeds** of the skip are calibrated according to the required production capacity.

The **cement weighing hopper** and the **water weighing hopper** rest on a support structure hinged to the front part of the mixing unit.

- MIXING UNIT WITH HORIZONTAL TWIN SHAFT MIXER: POWER AND EFFICIENCY
- PRE-ASSEMBLED AND PRE-WIRED MONOBLOCK THAT SIGNIFICANTLY REDUCES INSTALLATION AND START-UP TIME
- MAXIMUM MOBILITY AND TRANSPORTABILITY
- EXTREMELY VERSATILE FOR HIGH PRODUCTION CAPACITY PLANTS
- SIMPLE TO USE

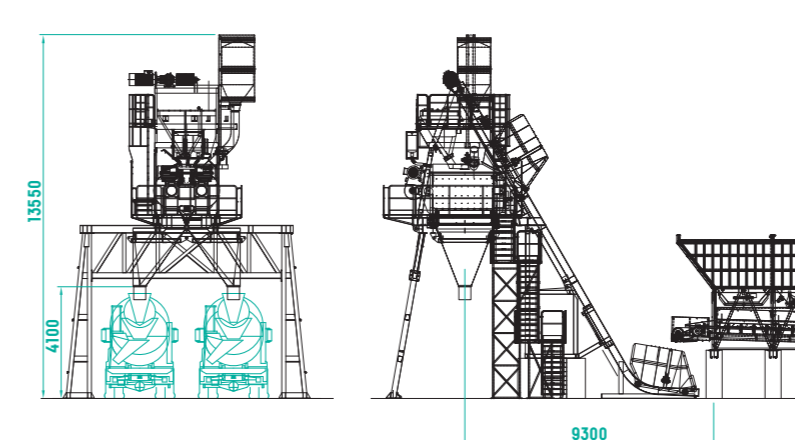

ORUDAY 100\_110\_125\_130 mixing unit with built-in skip and cabin even during transport phases



ORU DAY 150D mixing unit with built-in skip and cabin even during transport phases. Wider entrance to load several truck mixers thanks to the BYPASS system

# GENERAL LAYOUT

## ORUDAY 70L WITH STRAIGHT BELT

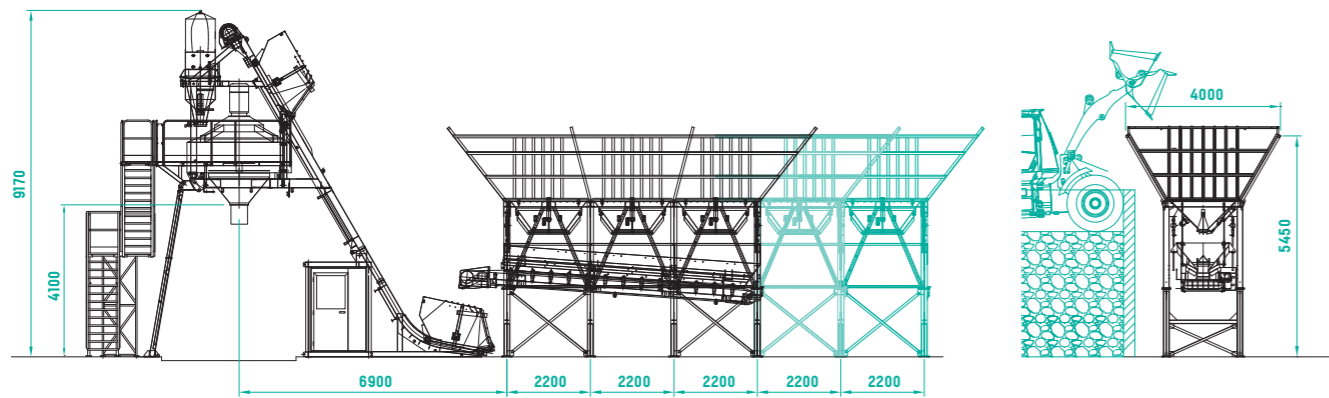

## ORUDAY 100\_110\_125\_130B WITH BELTUP

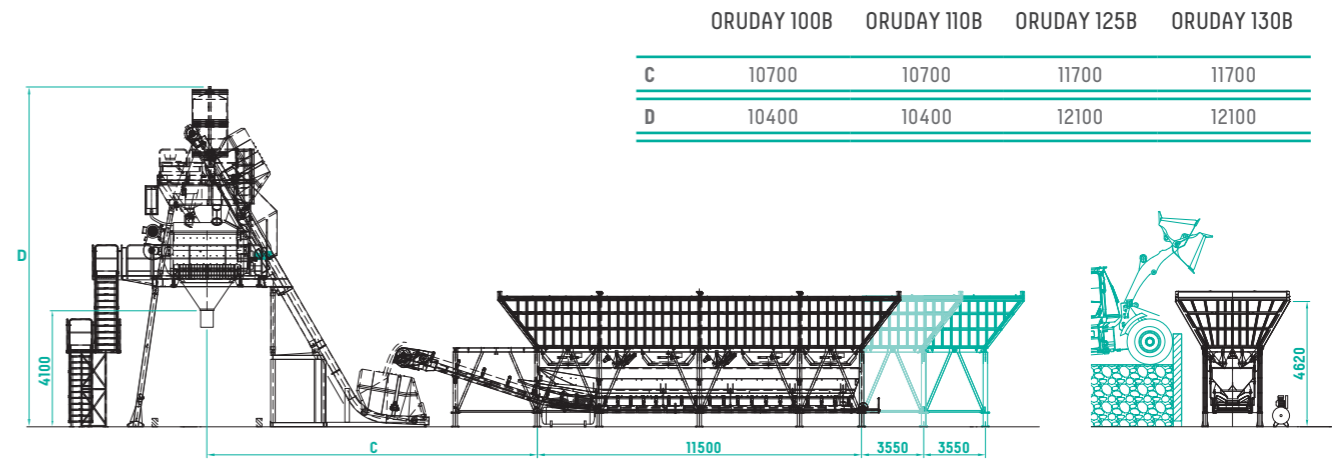

## ORUDAY 70L WITH BELTUP

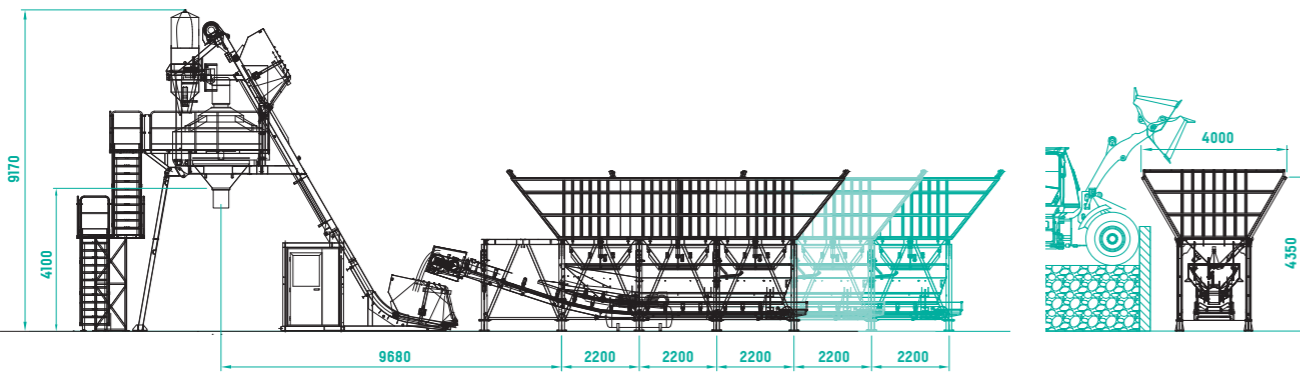

## ORUDAY 150DL WITH BELTUP

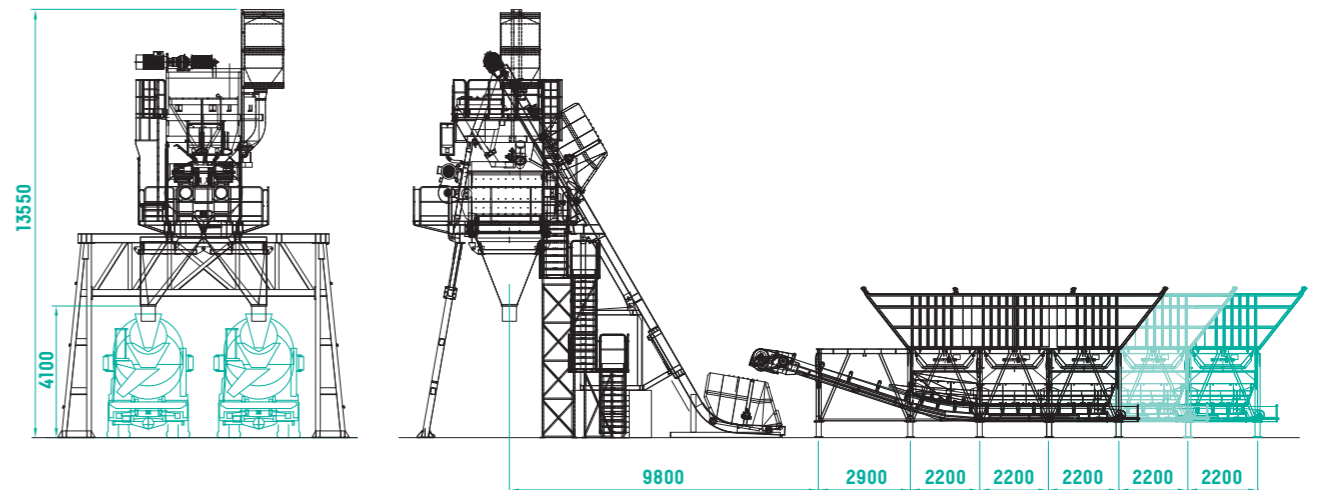



**LEBANON**

*ORUDAY 100L with LOGIK WL5 storage unit equipped with ORU MD 3000/2000 horizontal twin shaft mixer. Ideal for ready-mixed concrete production for construction and structural works in sites that must guarantee high performance.*

**EASY TO TRANSPORT  
AND FAST TO INSTALL**



**TRANSPORTABLE AND PRE-ASSEMBLED**

70L



**BY ROAD**  
1 LOW BED TRUCK  
+ 2 STANDARD TRUCKS (13.60M)



**BY SEA**  
1X40' FR H=3250 + 1X40' OT  
+ 1X40' OT H=2450

100-110L and B



**BY ROAD**  
LOW BED TRUCK  
+ 2 STANDARD TRUCKS (13.60M)



**BY SEA**  
1X40' FR H=3250 + 1X40' OT  
+ 1X40' OT H=2450

125-130L and B



**BY ROAD**  
LOW BED TRUCK  
+ 2 STANDARD TRUCKS (13.60M)



**BY SEA**  
1X40' FR H=3250 + 2X40' OT  
+ 1X20' OT H=2500

150DL and B



**BY ROAD**  
1 LOW BED TRUCK + 2 STANDARD  
TRUCKS (13.60M)  
+ 6 M OF TRUCK



**BY SEA**  
1X40' FR H=3250+2X40' OT  
+ 1X40' OT H=2500 + 1X20' OT

*Transport valid for the standard configuration.*

## ORUDAY MS ASSEMBLY PHASES



1

TRANSPORT  
CONFIGURATION

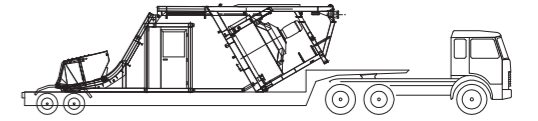

2

UNLOADING  
PHASE

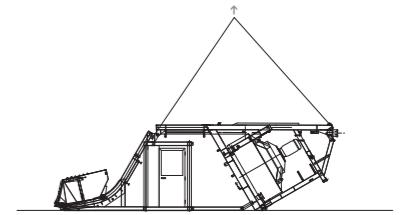

3

LIFTING  
OF THE MIXING UNIT

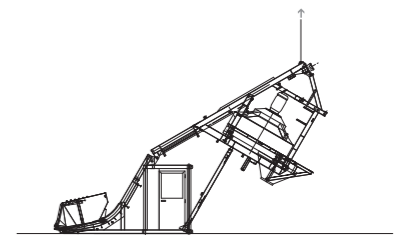

4

COMPLETELY  
ASSEMBLED  
BATCHING PLANT

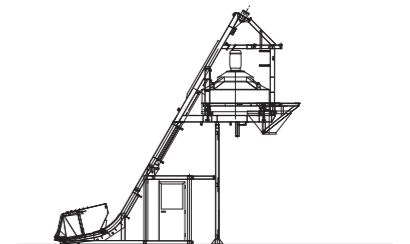



# ORUDAY MD PHASES ASSEMBLY

**1**  
TRANSPORT  
CONFIGURATION

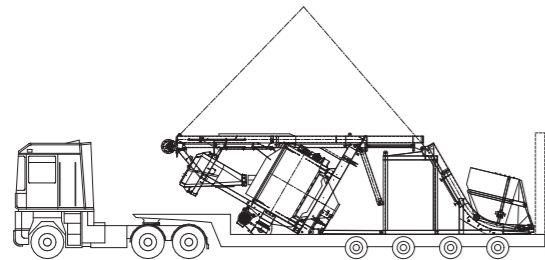

**2**  
UNLOADING  
PHASE

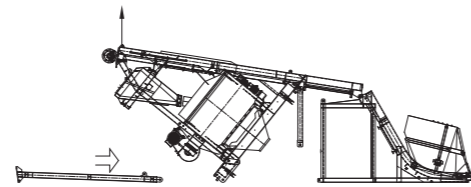

**3**  
LIFTING  
OF THE MIXING UNIT

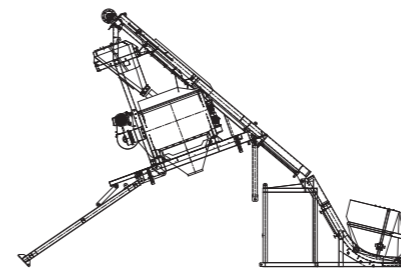

**4**  
COMPLETELY ASSEMBLED  
BATCHING PLANT

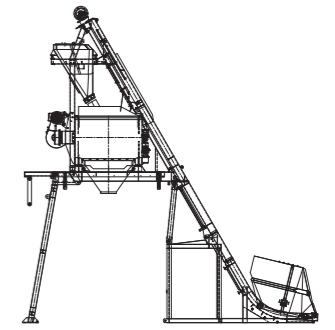



## AGGREGATES STORAGE UNITS

The **ORUDAY** batching plants can be equipped with different types of aggregates storage units for maximum versatility and adaptability:

### ORU CUBE

(CUBE-B with 2 bins for 3 or 4 aggregates)

### ORU LOGIK

(LOGIK-L with 3-4 or 5 bins,  
LOGIK-B with 4-5 or 6 bins)

### ORU ROME

(ROME CZ with 5-6-7 or 8 bins)

### CAMERUN

**ORUDAY 100B with LOGIK WB4 storage unit equipped with ORU MD 3000/2000 horizontal twin shaft mixer. Ideal for ready-mixed concrete production for construction and structural works in sites that must guarantee high performance.**

### TECHNICAL CHARACTERISTICS - (Standard configuration)

		ORUDAY 70L	ORUDAY 100L	ORUDAY 110L	ORUDAY 125L	ORUDAY 130L	ORUDAY 150DL	ORUDAY 100B	ORUDAY 110B	ORUDAY 125B	ORUDAY 130L	ORUDAY 150DB
Hourly production	m <sup>3</sup> /h	70	100	110	125	130	150	100	110	125	130	150
Batch capacity (vibrated concrete)	m <sup>3</sup>	1,5	2	2,5	3	3,35	3,35	2	2,5	3	3,35	3,35
Power required	kW	97	112	125	168	183	183	120	132	174	190	190
Planetary mixer	mod	ORUMS 2250/1500S	-	-	-	-	-	-	-	-	-	-
Twin shaft mixer	mod	-	ORUMD 3000/2000	ORUMD 3750/2500	ORUMD 4500/3000	ORUMD 5000/3350	ORUMD 5000/3350	ORUMD 3000/2000	ORUMD 3750/2500	ORUMD 4500/3000	ORUMD 5000/3350	ORUMD 5000/3350
Skip (speed)	m/s	0,55	0,58	0,58	0,61	0,61	0,61	0,58	0,58	0,61	0,61	0,61
Cement weighing hopper	l	735	1600	1600	2000	2000	2000	1600	1600	2000	2000	2000
Water weighing hopper	l	600 (optional)	800	800	1000	1000	1000	800	800	1000	1000	1000
Aggregates storage (capacity)	m <sup>3</sup>	65+210	65+210	65+210	65+210	65+210	with loading cells	with loading cells	with loading cells	with loading cells	with loading cells	with loading cells
Weighing system (type-approved)	mod	with loading cells	with loading cells	with loading cells	with loading cells	with loading cells	65+210	98+352	98+352	98+352	98+352	98+352
Aggregates hygrometer probe (microwave) (recommended optional)	mod	PK-3	PK-3	PK-3	PK-3	PK-3	PK-3	PK-3	PK-3	PK-3	PK-3	PK-3
Additives system (recommended optional)	l/min	2x12	3x24	3x24	3x45	3x45	3x45	3x24	3x24	3x45	3x45	3x45
Electric compressor (recommended optional)	mod	B6000	B7000	B7000	B7000	B7000	B7000	B7000	B7000	B7000	B7000	B7000
Management unit (recommended version)	mod	HPS 2100V	HPS 2100V	HPS 2100V	HPS 2100V	HPS 2100V	HPS 2100V	HPS 2100V	HPS 2100V	HPS 2100V	HPS 2100V	HPS 2100V

MOBILE WET

# ORUONEDAY

ORU ONEDAY is a pre-wired and pre-assembled mobile batching plant that has been engineered in order to meet the growing requirements of reducing time and space in the yard.

Its compact structure allows the immediate passage from the transport configuration to the operational one.

It is equipped with control cabin and weighing skip incorporated in the structure during the transportation phases too.

The entire plant is designed for maximum optimization of its transportability and for reducing transport costs to a minimum.



MIXING SYSTEM WITH  
PLANETARY MIXERS ORU MS  
OR TWIN SHAFT MIXERS ORU MD

EASIER TRANSPORTABILITY

MAXIMUM COMPACTNESS

MAXIMUM RELIABILITY

PRODUCT RANGE

ORUONEDAY 75

ORUONEDAY 95

ORUONEDAY 105

ORUONEDAY 120

ORUONEDAY 125



EGYPT

*ORUONEDAY 75 with built-in 100m<sup>3</sup> capacity storage unit equipped with ORU MS 2250/1500S planetary mixer. Ideal for ready-mixed concrete production for construction in sites where mobility and fast installation are essential.*

# GENERAL LAYOUT

ORUONEDAY 75 LOADING BY CONVEYOR BELT

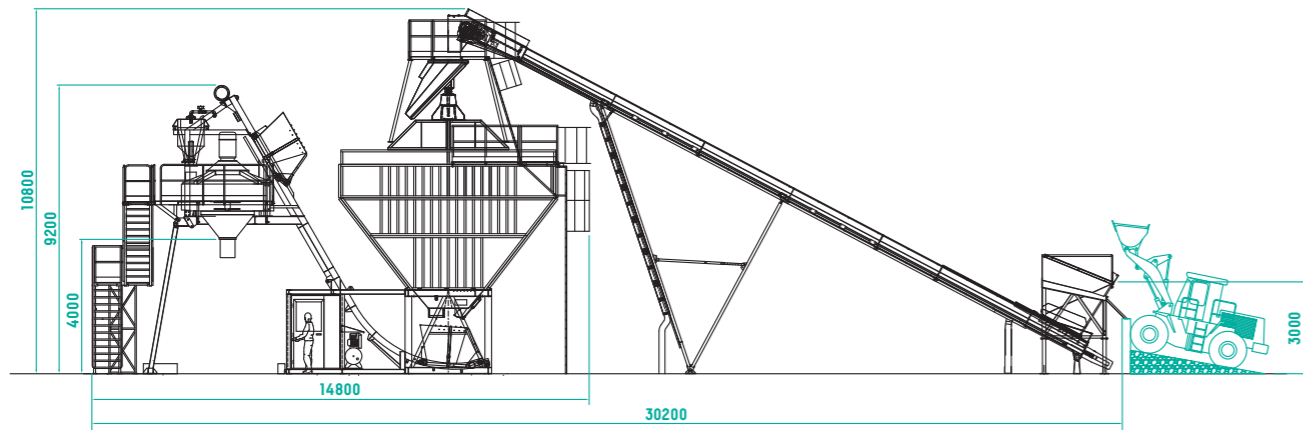

ORUONEDAY 95\_105\_120\_125 LOADING BY CONVEYOR BELT

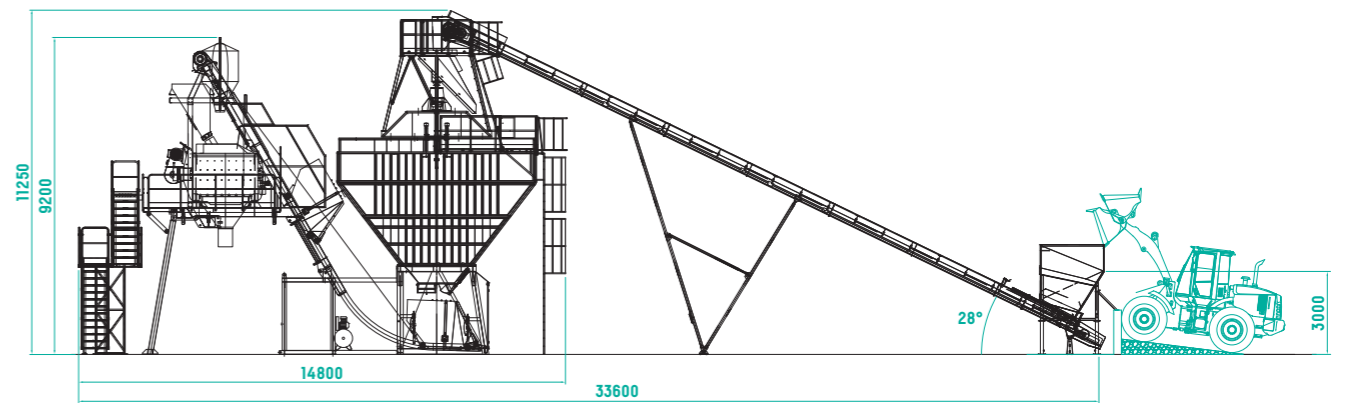

ORUONEDAY 75 LOADING BY PAYLOADER

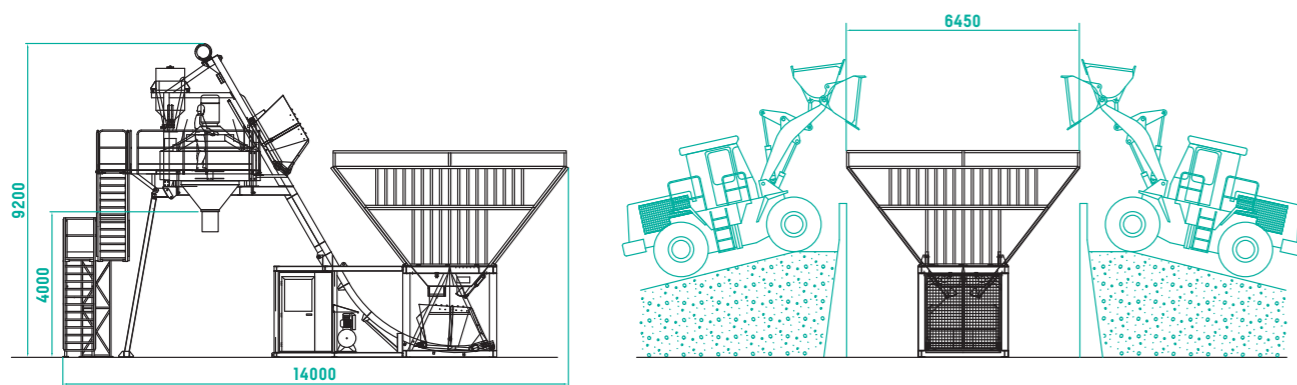

ORUONEDAY 95\_105\_120\_125 LOADING BY PAYLOADER

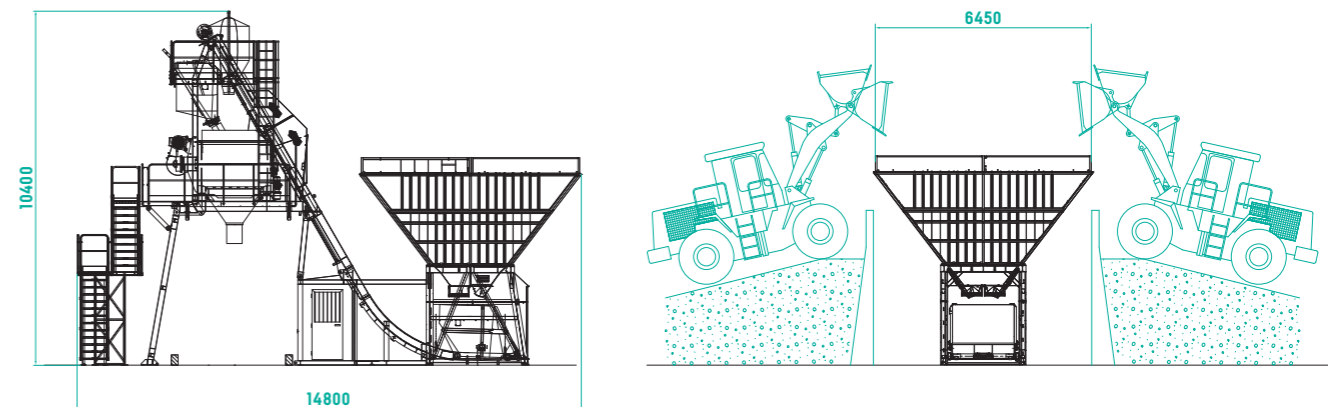



**POLAND**

*ORUONEDAY 105 with built-in 100 m<sup>3</sup> capacity storage unit, equipped with ORU MD3750/2500 horizontal twin shaft mixer and aggregate belt loading system with rotating distributor. Ideal for ready-mixed concrete production for construction in sites where mobility and fast installation are essential.*

38

## EASY TO TRANSPORT AND FAST TO INSTALL



### EASY TO TRANSPORT AND FAST TO INSTALL

#### ORUONEDAY MS

- MECHANICAL SHOVEL LOADING
- BY ROAD**  
1 LOW BED TRUCK +  
1 STANDARD TRUCK (13.6 M)
  - BY SEA**  
1X40' FR H=3250 + 1X40' OT

- CONVEYOR BELT LOADING
- BY ROAD**  
1 LOW BED TRUCK +  
2 STANDARD TRUCKS (13.6 M)
  - BY SEA**  
1X40' FR H=3250 + 2X40' OT

#### ORUONEDAY MD

- MECHANICAL SHOVEL LOADING
- BY ROAD**  
1 LOW BED TRUCK +  
1 STANDARD TRUCK (13.6 M)
  - BY SEA**  
1X40' FR H=3250 + 1X40' OT  
+ 1X20' OT

- CONVEYOR BELT LOADING
- BY ROAD**  
1 LOW BED TRUCK +  
2 STANDARD TRUCKS (13.6 M)
  - BY SEA**  
1X40' FR H=3250 + 2X40' OT

*Transport valid for the standard configuration.*

39



### AIRBAG

The mixing unit is fitted with an expansion chamber used for collecting the dusty air that comes out under pressure from the mixer when aggregates and cement flow in.

### SAFETY SYSTEM

A set of electro-mechanical limit switches and stopping systems make the skip operation extremely safe. The drum is characterized by grooves that ensure a single winding layer of the cable and avoid the fretting wear of two contiguous cable coils (single coil/single groove).

### WEIGHING SKIP

The skip is fitted with a gravity discharge gate and rests on a rail along which a weighing system is installed. Through the said device, the aggregates, once metered, are weighed and transported into the mixer.

### AGGREGATES STORAGE BINS CAPACITY

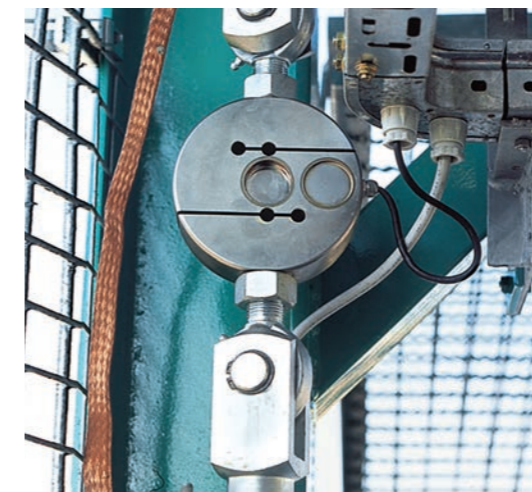
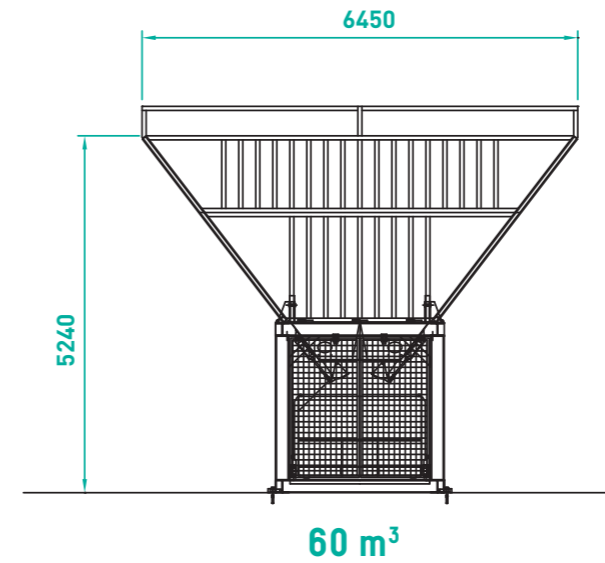
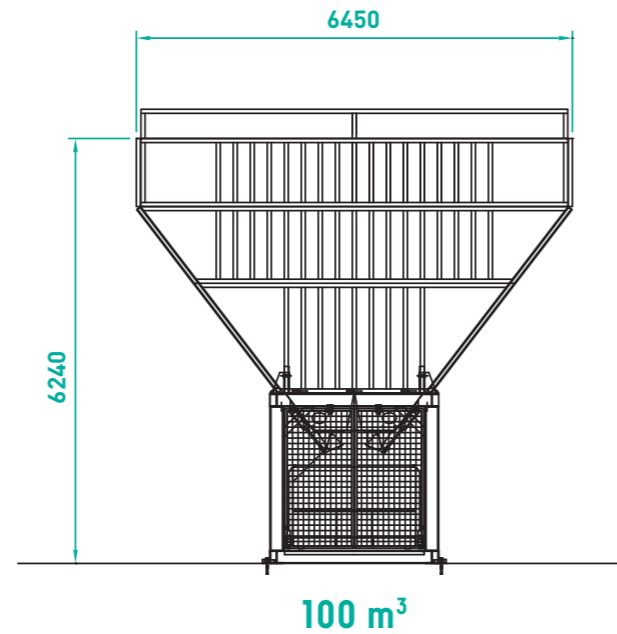

### PRE-WIRING

In order to meet the requirements of speed, versatility and compactness, ORU ONEDAY is entirely pre-wired. This operational solution significantly reduces the installation and commissioning time of the batching plant.



### WEIGHING SYSTEM

The weighing of water, aggregates and cement takes place separately and simultaneously with independent phases by means of load cells applied to supports that ensure the biggest metering accuracy and reliability. To guarantee an extreme accuracy during the metering phase, the discharge of aggregates from the various storage sectors takes place through pneumatically-operated gates and by a "spilling and jogging" system.

## MIXING UNIT DISTINCTIVE FEATURES



ORU ONEDAY MS concrete batching plant with aggregate storage, control cabin and incorporated weighing skip. Aggregates loading by conveyor belt.

- SYSTEM EQUIPPED WITH PLANETARY MIXER OR TWIN SHAFT MIXER AND BUILT-IN WEIGHING SKIP AND FULLY HOT-GALVANISED, BUILT-IN STORAGE BINS
- ALL IN A PRE-ASSEMBLED AND PRE-WIRED MONOBLOCK TO QUICKLY SWITCH FROM TRANSPORT TO OPERATING MODE
- MAXIMUM MOBILITY AND TRANSPORTABILITY
- CONTROL CABIN BUILT INTO THE FRAME EVEN DURING THE TRANSPORT PHASE
- SIMPLE TO USE



ORU ONEDAY MD concrete batching plant with aggregate storage, control cabin and incorporated weighing skip. Aggregates loading by payloader.

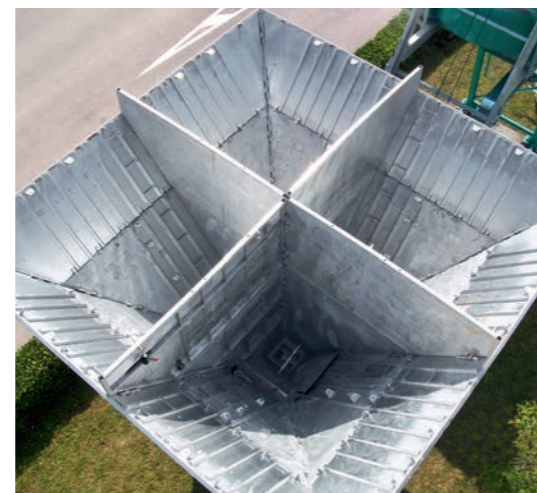

Storage bins, intermediate walls and discharge mouths fully heat galvanised

## ORU ONEDAY AGGREGATE STORAGE

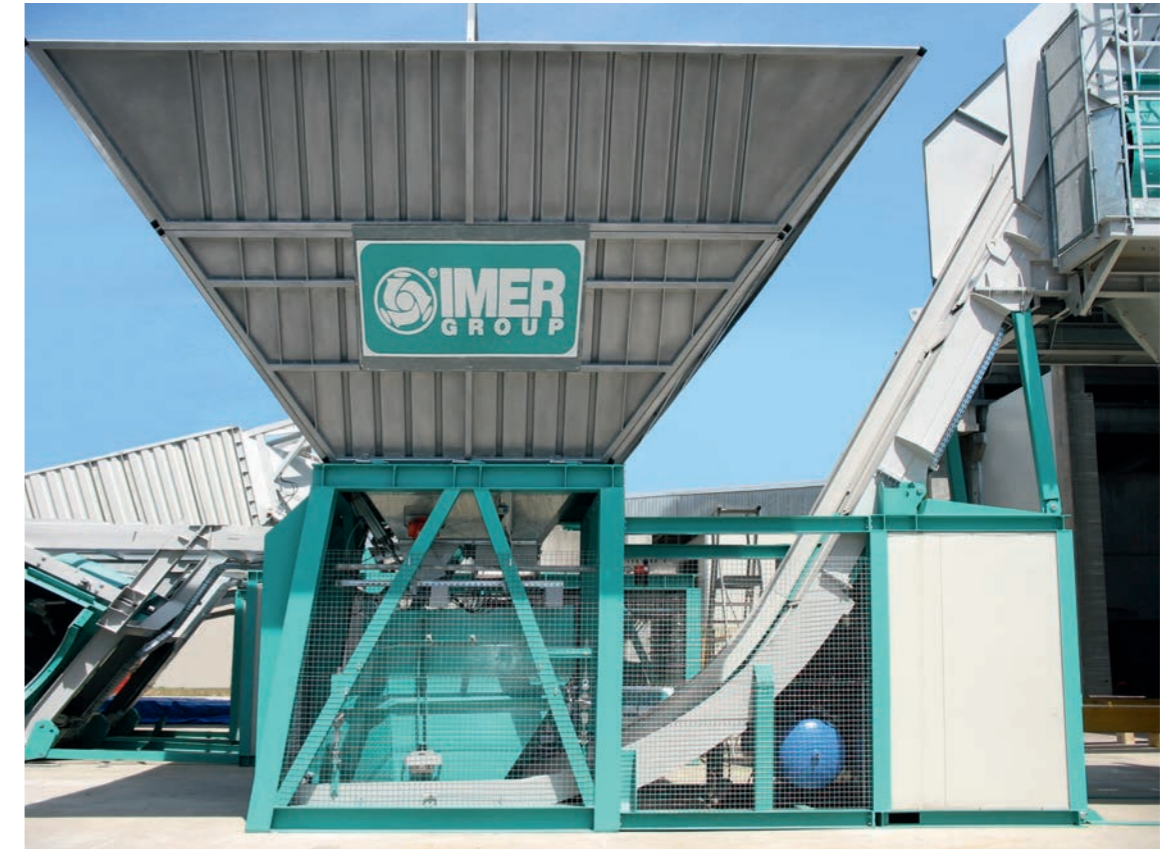

Aggregate storage ONEDAY with weighing skip

- AGGREGATE LOADED BY MECHANICAL SHOVEL OR BELT WITH ROTATING DISTRIBUTOR
- EXCELLENT AGGREGATE SLIDING COEFFICIENT
- EXPANDED DISCHARGE MOUTHS FOR HIGH PRODUCTIVITY
- HIGHLY COMPACT DUE TO THE WEIGHING SKIP



Rotating distributor

# ORU ONEDAY TECHNICAL DATA



FRANCE

*ORUONEDAY 75 with built-in 100 m<sup>3</sup> capacity storage unit, equipped with ORU MS 2250/1500S planetary mixer and aggregate belt loading system with rotating distributor. Ideal for ready-mixed concrete production for construction in sites where mobility and fast installation are essential.*

## ORUONEDAY MS - TECHNICAL CHARACTERISTICS - (Standard configuration)

Hourly production	m <sup>3</sup> /h	75
Batch capacity (vibrated concrete)	m <sup>3</sup>	1,5
Power required	kW	100
Conveyor belt loading system (power required)	kW	15
Planetary mixer	mod	ORUMS 2250/1500S
Skip (speed)	m/s	0,55
Cement weighing hopper	l	735
Water weighing hopper	l	600
Aggregates storage (capacity)	m <sup>3</sup>	60/100
Weighing system (type-approved)	mod	with loading cells
Aggregates hygrometer probe (microwave) (recommended optional)	mod	PK-3
Additives system (recommended optional)	n°/l	2x24
Electric compressor (recommended optional)	mod	B6000
Management unit	mod	HPS 2100V

## ORUONEDAY MD TECHNICAL CHARACTERISTICS - (Standard configuration)

		ORUONEDAY 95	ORUONEDAY 105	ORUONEDAY 120	ORUONEDAY 125
Hourly production	m <sup>3</sup> /h	95	105	120	135
Batch capacity (vibrated concrete)	m <sup>3</sup>	2	2.5	3	3.35
Power required	kW	112	125	165	180
Conveyor belt loading system (power required)	kW	18	18	18	18
Twin shaft mixers	mod	ORUMD 3000/2000	ORUMD 3750/2500	ORUMD 4500/3000	ORUMD 5000/3350
Skip (speed)	m/s	0,55	0,55	0,55	0,55
Cement weighing hopper	l	1600	1600	2000	2000
Water weighing hopper	l	800	800	1000	1000
Aggregates storage (capacity)	m <sup>3</sup>	60/100	60/100	60/100	60/100
Weighing system (type-approved)	mod	with loading cells	with loading cells	with loading cells	with loading cells
Aggregates hygrometer probe (microwave) (recommended optional)	mod	PK-3	PK-3	PK-3	PK-3
Additives system (recommended optional)	n°/l	3x24	3x24	3x45	3x45
Electric compressor (recommended optional)	mod	B7000	B7000	B7000	B7000
Management unit	mod	HPS 2100V	HPS 2100V	HPS 2100V	HPS 2100V



## STATIONARY BATCHING PLANTS





STATIONARY

# ORULK

ORU LK is a range of compact and flexible stationary batching plants. The structure of the plant consists of multiple modular elements aimed at making the system fully adaptable to different worksite and production needs.



MIXING SYSTEM  
WITH PLANETARY MIXERS ORU MS  
OR TWIN SHAFT MIXERS ORU MD



STURDY

POWERFUL

VERSATILE

## PRODUCT RANGE

ORULK 80T

ORULK 100T

ORULK 120T

ORULK 125T

ORULK 130T

ORULK 150TD



ITALY

*ORU LK 130TB with belt loading system and aggregate standby hopper, ideal for ready-mixed concrete production for large projects and structural works.*

## MIXING UNIT WITH STANDBY HOPPERS

The mixing unit is the heart of the system. In this configuration, it is equipped with an ORUMD 3750/2500 mixer with double horizontal axis that allows different types of concrete to be mixed, always guaranteeing the highest quality.

The mixing unit is also fitted with standby hoppers that serve as a reserve "buffer", thus cutting down to a minimum the time needed to load the mixer for a system with very high performance.

The system features an expansion chamber (airbag) that collects the air full of dust created by the aggregates and by the cement after they enter the mixer.

## AGGREGATES STORAGE UNIT WITH BELTUP

The aggregates storage and batching unit is modular, sturdy and completely hot galvanised in order to guarantee maximum resistance over time and a long service life.

Thanks to the BELTUP weighing belt (patented), no burdensome concrete works are necessary (no pillars or pits) and the loading point of the storage tanks stays extremely low.



## AGGREGATES TRANSFER BELT

The aggregates are transferred from the storage unit to the mixer by means of a conveyor belt designed in sync with the logic of modularity, transportability and versatility typical of all the other system components. The belt has a gangway for maintenance purposes, guards for total protection and safety devices. The structure is entirely hot galvanised.



## AGGREGATES STORAGE UNITS

The **ORULK** batching plants can be equipped with different types of aggregates storage units, for maximum versatility and adaptability:

### ORU LOGIK

(LOGIK-L with 3-4 or 5 bins,  
LOGIK-B with 4-5 or 6 bins)

### ORU ROME

(ROME CZ with 5-6-7 or 8 bins)

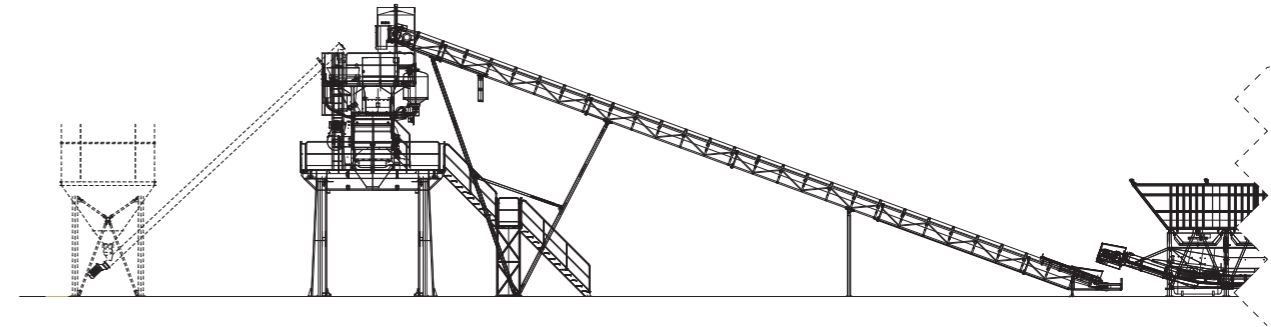

### TECHNICAL CHARACTERISTICS - (Standard configuration)

		ORULK 80TL	ORULK 100TL	ORULK 120TL	ORULK 125TL	ORULK 130TL	ORULK 150TDL	ORULK 80TB	ORULK 100TB	ORULK 120TB	ORULK 125TB	ORULK 130TB	ORULK 150TDB
Hourly production	m <sup>3</sup> /h	78	100	120	125	130	150	78	100	120	125	130	150
Batch capacity (vibrated concrete)	m <sup>3</sup>	1,5	2	2,5	3	3,35	3,35	1,5	2	2,5	3	3,35	3,35
Power required	kW	97	112	125	168	183	196	97	117	130	167	183	200
Planetary mixer	mod	ORUMS 2250/1500S	-	-	-	-	-	ORUMS 2250/1500S	-	-	-	-	-
Twin shaft mixer	mod	-	ORUMD 3000/2000	ORUMD 3750/2500	ORUMD 4500/3000	ORUMD 5000/3350	ORUMD 5000/3350	-	ORUMD 3000/2000	ORUMD 3750/2500	ORUMD 4500/3000	ORUMD 5000/3350	ORUMD 5000/3350
Loading belt (length)	m	26	29	29	30	30	35	26	29	29	30	30	35
Loading belt (width)	m	0,8	0,8	0,8	1	1	1	0,8	0,8	0,8	1	1	1
Loading belt (flow)	m <sup>3</sup> /h	266	266	266	510	510	510	266	266	266	510	510	510
Cement weighing hopper	l	735	1400	1400	2000	2000	2000	735	1400	1400	2000	2000	2000
Water weighing hopper	l	600	700	700	1000	1000	1000	600	700	700	1000	1000	1000
Aggregates storage (capacity)	m <sup>3</sup>	65÷210	65÷210	65÷210	65÷210	65÷210	65÷210	65÷210	98÷352	98÷352	98÷352	98÷352	65÷210
Weighing system (type-approved)	mod	with loading cells	with loading cells	with loading cells	with loading cells	with loading cells	with loading cells	with loading cells	with loading cells	with loading cells	with loading cells	with loading cells	with loading cells
Aggregates hygrometer probe (microwave) (recommended optional)	mod	PK-3	PK-3	PK-3	PK-3	PK-3	PK-3	PK-3	PK-3	PK-3	PK-3	PK-3	PK-3
Additives system (recommended optional)	l/min	2x12	3x24	3x24	3x45	3x45	3x45	2x12	3x24	3x24	3x45	3x45	3x45
Electric compressor (recommended optional)	mod	B6000	B7000	B7000	B7000	B7000	B7000	B6000	B7000	B7000	B7000	B7000	B7000
Management unit	mod	HPS 2100V	HPS 2100V	HPS 2100V	HPS 2100V	HPS 2100V	HPS 2100V	HPS 2100V	HPS 2100V	HPS 2100V	HPS 2100V	HPS 2100V	HPS 2100V



STATIONARY

# ORUZENITH

## BATCHING PLANT WITH VERTICAL AGGREGATES STORAGE SYSTEMS

In accordance with the general philosophy underlying ORU's commercial policy, the vertical batching plants are designed to provide an answer to specific requirements.

The choice of a vertical batching plant presupposes a greater output compared to a horizontal plant and offers an excellent possibility of controlling noise and dust emissions.

The vertical system requires in fact the material to be raised, but thereafter the whole process takes place in a closed environment and by gravity, with distinct advantages in terms of energy savings, less wear, and reduced external noise levels.

The combination of the most modern technologies with trained personnel makes it possible to obtain a system capable of reconciling productivity and quality of the product and of best meeting operating demands.



### MIXING SYSTEM WITH PLANETARY MIXERS ORU MS OR TWIN SHAFT MIXERS ORU MD

The **ORU ZENITH** vertical batching plants are the ideal solution in the cases requiring:

- High productivity (with different aggregate types)
- High storage capacity and reduced spaces
- A variety of functions (both for the pre-cast industry and for ready-mix concrete)
- Functionality (thanks to the philosophy of modular construction).

### PRODUCT RANGE

ORUZENITH MID6

ORUZENITH MID8

ORUZENITH BIG10

## MODULAR CONSTRUCTION AND HOT GALVANIZING

To simplify construction and handling, and cut down delivery times, ORU has standardized some elements that are common to all versions.

These elements include walls, extension walls and partitions, aggregate hoppers, the weighing conveyor belt frame, and the frame of the hopper with two discharge gates.

The support structure and the aggregate storage bins are hot galvanized.



This type of surface treatment of the metal ensures an excellent protection against corrosion in any environmental condition, and therefore a longer life and better inalterability of the product.

On request, the equipment can also be provided with paint coating over the galvanized surfaces.



It consists of a cylindrical silo whose lower part has the shape of a truncated cone and which is characterized by:

- **Rationality of aggregate flowing**
- **Easy conveying into the weighing hopper even in the presence of a great number of aggregates**
- **Possibility of conveying the water coming out of very moist aggregates into collecting areas: it is indispensable to collect the water both for carrying out high-quality batches and for the environmental respect and cleaning**
- **Simple assembly: the silos are constructed by means of galvanized modular panels (both the cylindrical part and the truncated cone) of suitable dimensions in order to facilitate their transport and assembly; each panel is 2 metres high in order to allow a quick and safe assembly on the ground, thus avoiding the use of scaffolds and cranes**
- **Elimination of all the aggregate residues thanks to its shape**
- **Easy maintenance: in the lower truncated-conical part where the extraction mouths are positioned, a crawl space (one for each compartment) allows the internal maintenance**
- **Sturdiness of the pneumatically-operated extraction mouths (on request: wear-resistant plates)**



## AGGREGATE STORAGE AND COVERS

The dimensions of the compartments are such as to allow a considerable filling capacity, and the modularity of the hoppers simplifies their installation. The aggregate storage bin charging system is made to meet the specific requirements of each building yard.

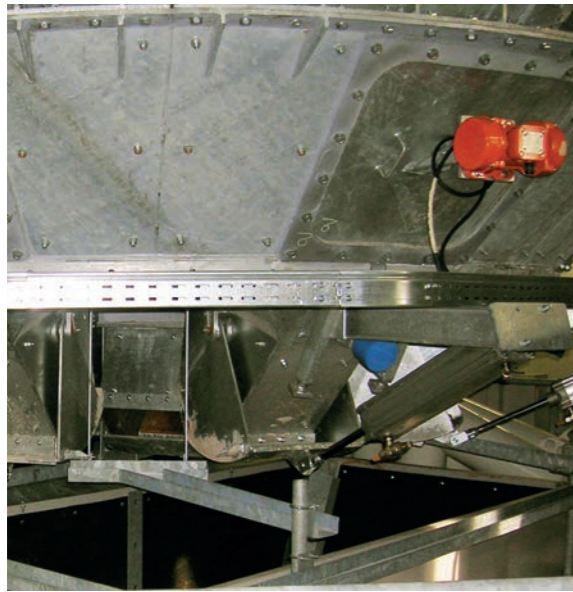

### VIBRATING SYSTEM

To facilitate the discharge of particularly cohesive materials, vibrators have been installed on independent plates applied with a particular system to avoid negative stresses on the plant structure.

### PNEUMATIC DISCHARGE GATES

The aggregate is fed from the hoppers through electro-pneumatic discharge gates, with double speed in the closing phase. On request, the discharge systems can be of different type (by belt conveyor, by vibrating conveyors, etc.) and tailored to the requirements of the customer. When the aggregate is discharged through electro-pneumatic gates, the use of an adjustable mechanical limit switch controlling the opening of the discharge gate guarantees greater batching accuracy.

### EXTRACTOR BELT

When high metering accuracy is necessary in feeding materials such as sand or crushed stone, the use of the extracting conveyor belt is a sure solution to the problem. The machine is equipped with a device signalling the presence of material, a flow regulator, and a manual cut-off gate for routine maintenance.



### DOUBLE WEIGHING SYSTEM AND TOP PERFORMANCE

The vertical plants ORU ZENITH can be equipped in the dual mixer configurations with double independent weighing systems to ensure maximum hourly production.



### STORAGE BINS

The aggregates storage consists of a cylindrical silo whose lower part has a truncated-conical shape and which is characterized by:

- **Rationality of aggregate flowing**
- **Elimination of all the aggregate residues thanks to its shape**
- **Easy conveying into the weighing hopper even in the presence of a great number of aggregates**



### WEIGHING SYSTEM

The aggregate and cement weighing system uses load cells applied directly to the supports of the respective hoppers, thus achieving an accurate and reliable weight measurement. The weighing system with load cells is type approved according to CE standards.



ORUZENITH MID6

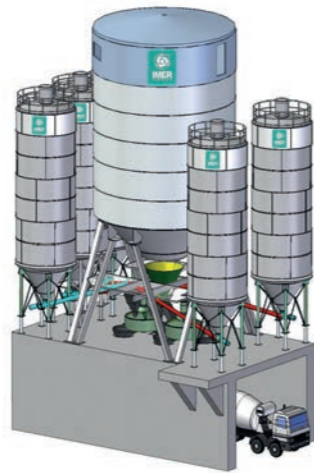

ORUZENITH MID8

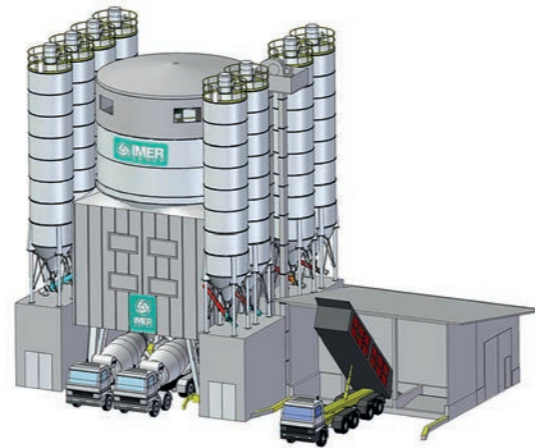

ORUZENITH BIG10

## TECHNICAL CHARACTERISTICS

		ORU ZENITH MID6	ORU ZENITH MID8	ORU ZENITH BIG10
Aggregates storage bins	n	6+12	8+16	10+18
Aggregates storage capacity	m <sup>3</sup>	160÷390	270÷780	480÷1.450
Aggregates weighing hopper capacity	kg		2.400÷10.000	
Cement weighing hopper capacity	kg		600÷2.400	
Approved weighing system		Loading cells		
Water system		By weight or by electromagnetic flow meter		
Mixer		Planetary (ORU MS) - Twin shaft (ORU MD)		

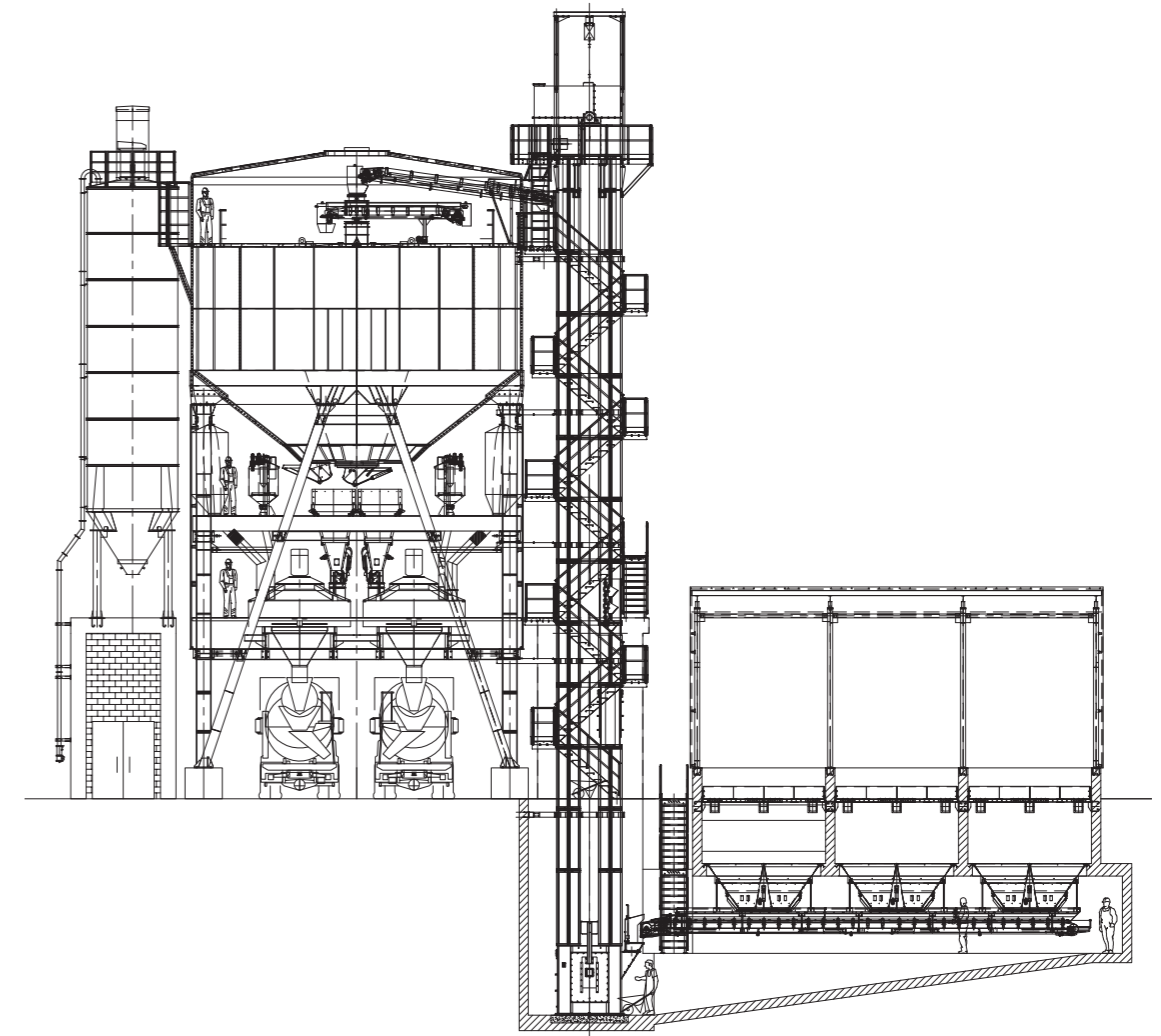
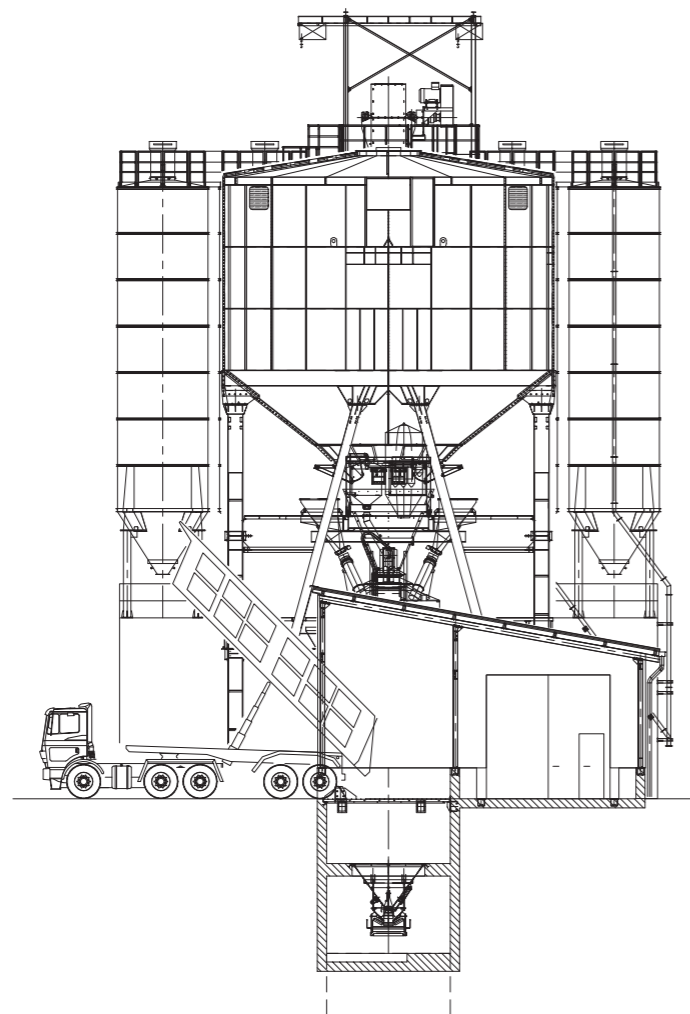



## AGGREGATE STORAGE SYSTEMS



# TECHNICAL CHARACTERISTICS

## STORAGE UNIT ORU ROME CZ

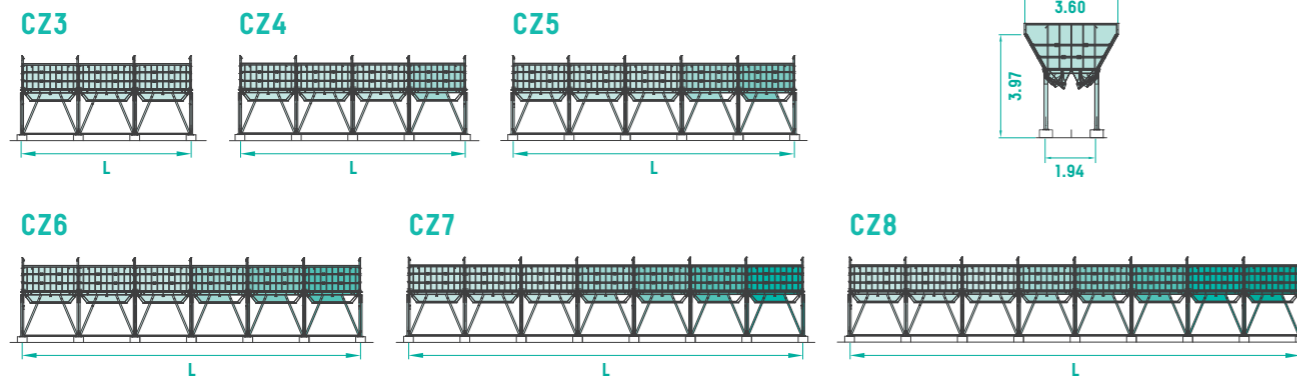

Storage (m³)	L (m)	WEIGHING BELT				
<b>CZ3</b>						
54	8.7	Width (m)	0.70	0.80	-	-
		Flow (m³/h)	190	266	-	-
		Length (m)	9.4	9.4	-	-
<b>CZ4</b>						
72	11.6	Width (m)	0.70	0.80	1.00	1.20
		Flow (m³/h)	190	266	350	460
		Length (m)	12.3	12.3	12.7	12.7
<b>CZ5</b>						
90	14.5	Width (m)	0.70	0.80	1.00	1.20
		Flow (m³/h)	190	266	350	460
		Length (m)	15.2	15.2	15.6	15.6

Storage (m³)	L (m)	WEIGHING BELT				
<b>CZ6</b>						
108	17.4	Width (m)	-	0.80	1.00	1.20
		Flow (m³/h)	-	266	350	460
		Length (m)	-	18.1	18.5	18.5
<b>CZ7</b>						
126	23,2	Width (m)	-	0.80	1.00	1.20
		Flow (m³/h)	-	266	350	460
		Length (m)	-	21	21.4	21.4
<b>CZ8</b>						
144	26,1	Width (m)	-	0.80	1.00	1.20
		Flow (m³/h)	-	266	350	460
		Length (m)	-	23.9	24.3	24.3



ORU ROME CZ

## STORAGE UNIT ORU CUBE S

FEATURES	
Aggregates storage capacity (m³)	20
Bins (n°)	4
Discharge gate (n°)	4

## WEIGHING BELTS

STRAIGHT BELT	
Width (m)	0.70
Flow (m³/h)	190
Length (m)	5.10

BELTUP	
Width (m)	0.80
Flow (m³/h)	266
Length (m)	6.00



ORU CUBE S

## STORAGE UNIT ORU CUBE B

Storage (m³)	Extension walls (m)	A (m)	C (m)	D (m)
54	0	4.40	0.00	0.70
82	1	5.40	1.00	1.70
110	2	6.40	2.00	2.70

FEATURES	
Bins (n°)	4
Discharge gate (n°)	4

## WEIGHING BELTS

STRAIGHT BELT	
Width (m)	0.70
Flow (m³/h)	190
Length (m)	5.10

BELTUP	
Width (m)	0.80
Flow (m³/h)	266
Length (m)	6.00

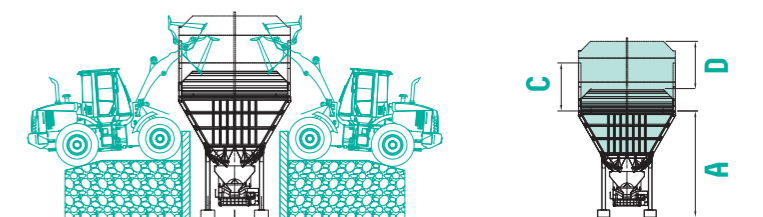

ORU CUBE B

## TECHNICAL CHARACTERISTICS

### STORAGE UNIT ORU LOGIK L3/4/5

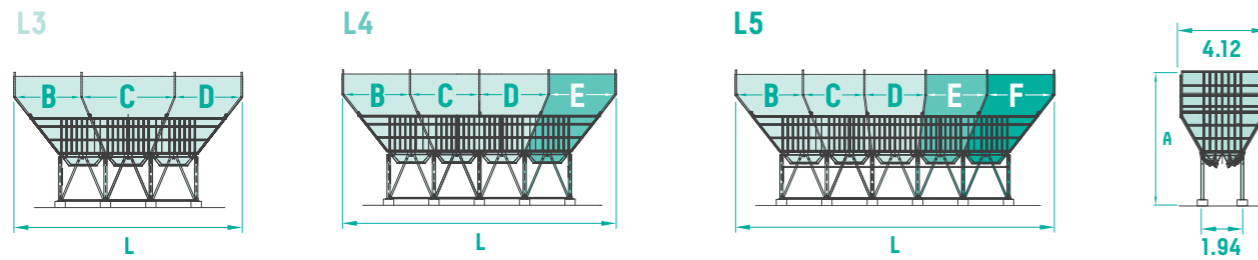

Storage (m <sup>3</sup> )	Extension walls (m)	A (m)	L (m)	B (m)	C (m)	D (m)	E (m)	F (m)
<b>L3</b>								
65	0	4.35	9.58	2.84	3.78	2.84		
105	1	5.35	11.25	3.24	4.65	3.24		
150	2	6.35	10.94	3.17	4.46	3.17		
<b>L4</b>								
80	0	4.35	11.78	2.84	2.96	2.96	2.84	
130	1	5.35	13.45	3.24	3.39	3.39	3.24	
180	2	6.35	13.14	3.17	3.30	3.30	3.17	
<b>L5</b>								
100	0	4.35	13.99	2.84	2.69	2.69	2.69	2.84
150	1	5.35	16.65	3.24	2.97	2.97	2.97	3.24
210	2	6.35	15.34	3.17	2.91	2.91	2.91	3.17

WEIGHING BELT	Straight Belt	Beltup
<b>L3</b>		
Width (m)	1.20	1.20
Flow (m <sup>3</sup> /h)	460	460
Length (m)	7.40	9.10
<b>L4</b>		
Width (m)	1.20	1.20
Flow (m <sup>3</sup> /h)	460	460
Length (m)	9.90	11.30
<b>L5</b>		
Width (m)	1.20	1.20
Flow (m <sup>3</sup> /h)	460	460
Length (m)	12.30	13.50

### STORAGE UNIT ORU LOGIK B4/5/6

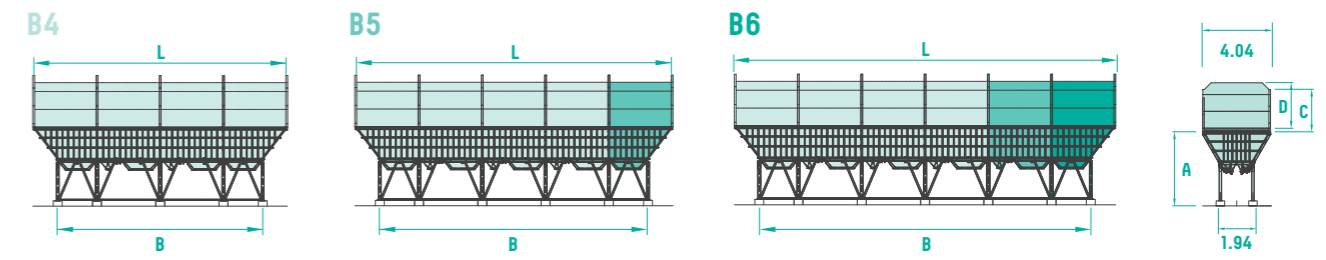

Storage (m <sup>3</sup> )	Extension walls (m)	A (m)	B (m)	C (m)	D (m)	L (m)
<b>B4</b>						
98	0	4.40		0.00	0.00	
122	0	4.40	11.5	0.50	0.70	14.2
178	1	5.40		1.50	1.70	
234	2	6.40		2.50	2.70	
<b>B5</b>						
124	0	4.40		0.00	0.00	
152	0	4.40	15.05	0.50	0.70	17.75
222	1	5.40		1.50	1.70	
294	2	6.40		2.50	2.70	
<b>B6</b>						
150	0	4.40		0.00	0.00	
184	0	4.40	18.6	0.50	0.70	21.3
268	1	5.40		1.50	1.70	
352	2	6.40		2.50	2.70	

WEIGHING BELT	Straight Belt	Beltup
<b>B4</b>		
Width (m)	1.20	1.20
Flow (m <sup>3</sup> /h)	460	460
Length (m)	12.70	14.30
<b>B5</b>		
Width (m)	1.20	1.20
Flow (m <sup>3</sup> /h)	460	460
Length (m)	16.00	17.80
<b>B6</b>		
Width (m)	1.20	1.20
Flow (m <sup>3</sup> /h)	460	460
Length (m)	19.40	21.30



ORU LOGIK WL



ORU LOGIK WB



## BELTUP WEIGHING BELTS

BELT-UP is a modular range of weighing belts devised to be combined with all the ORU storage units and easily interface them with the mixing units obtaining innovative, compact and cost-effective solutions. Thanks to its particular design, with large radius of curvature, the belt hopper gently accompanies the belt route ensuring optimum functionality.

A technical answer to dispense with the costs of concrete works for pits and pillars on the site, to make the installation of our plants quicker and cheaper. The aggregate loading point remains unchanged in all configurations.

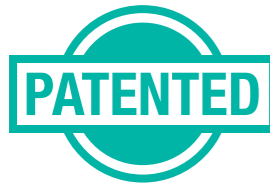

- NO CONCRETE PILLARS AND/OR SKIP PIT
- LOW AGGREGATE LOADING POINT WITHOUT REDUCING CAPACITY
- HORIZONTAL AGGREGATE WEIGHING SYSTEM AND MAXIMUM CAPACITY



## VF MOBILE RAMPS

By combining the CUBE B and CUBE S storage units with the VF (very fast) mobile ramps kit, installation times are significantly reduced and no concrete works are practically required.



- FULLY HOT-GALVANIZED MOBILE CONTAINMENT STRUCTURES
- QUICK AND EASY INSTALLATION
- NO CONCRETE WORKS
- MAXIMUM MOBILITY
- ALMOST NO COSTS FOR DEMOLITION AND CLOSING OF THE SITE



## MOBILE FOUNDATIONS

Our formworks for mobile foundations are designed for a simple positioning and laying.

When used the first time, they are filled with concrete. At this point, they become prefabricated single-blocks ready to be handled and reused at different work sites.

- QUICK INSTALLATION
- NO NEED TO WAIT FOR CURING OF THE CONCRETE
- INEXPENSIVE AND REUSABLE



## WINTER PACKAGE

All our plants are designed for the installation of all the technical devices and the insulation required to operate in extreme weather conditions.



- PROTECTION AGAINST THE ELEMENTS
- POSSIBILITY TO PRODUCE UNDER EXTREME CONDITIONS
- LESS ENVIRONMENTAL IMPACT

## MIXING SYSTEMS



MIXING



## IMER GROUP MIXERS

### RELIABILITY AND PERFECT MIXING

Mixing is the most important phase in the concrete production process.

Indeed concrete **quality** and **costs** depend on **mixing** quality.

IMER GROUP mixers are the result of the meticulous and systematic analysis of problems concerning mixing materials of different sizes, shapes, consistency and specific weight.

Extremely **sturdy**, **reliable** and **versatile**, mixers are built with wear-resistant materials that allow maintenance reduction and can be applied in multiple production fields.



### PLANETARY MIXERS

## ORUMS

ORU MS planetary vertical mixers with coaxial motor can quickly mix any type of concrete with excellent results: **dry**, **semi-dry** or **plastic**.

They are used in the ready-mix and precast sectors and in the production of materials such as glass, ceramics, refractory material, cold asphalt, etc.

### TWIN SHAFT MIXERS

## ORUMD

Thanks to our experience in the pre-mixing sector and to the introduction of technological innovations, the horizontal dual axis mixing line is able to pack **any type of concrete** (civil and industrial constructions, dams, lightweight concrete with low specific weight additives, mixes for foundations and stabilisers).

The ORU MD mixer line is equipped with two horizontal mixing axes rotating in sync in opposite directions.



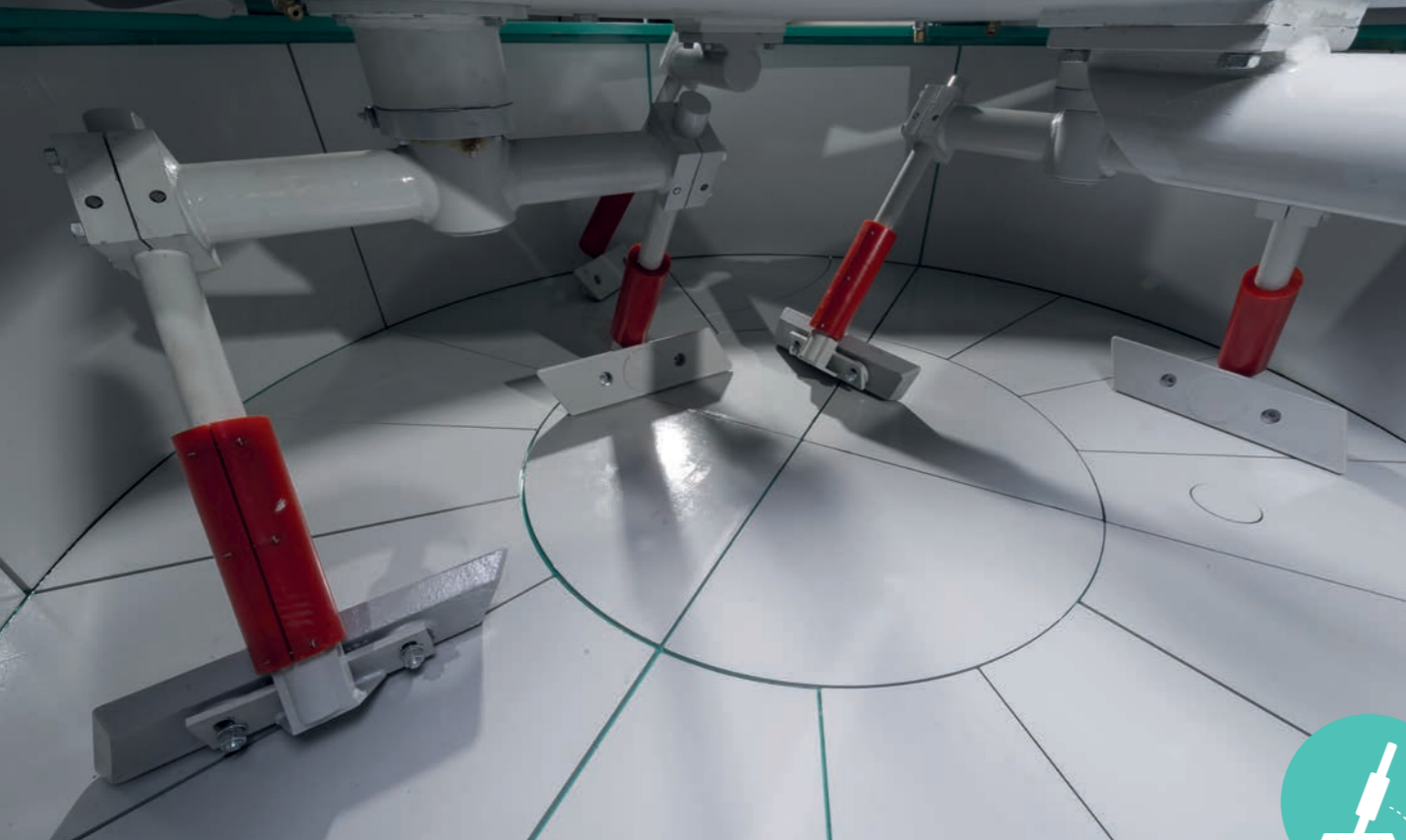

## ORUMS

### SCRAPER AND MIXER BLADES

The **blade angles of incidence and profiles** were carefully designed to best exploit available power, reducing mixing and discharge times to a minimum.

The entire material mass is involved thanks to the ideal angle, guaranteeing high mix homogeneity. The blades are reversible to extend their working lives. Significant time savings and less wear are due to such an efficient mixing system.

Each mixing star holds **two or three** special steel **arms** with high elasticity, according to the model.

The **rounded arm shape** contributes to the lack of material accumulation during the mixing and discharge phases. The arms are coated with **wear-resistant lining** that guarantees "almost eternal" durability. Thanks to the fall stop system, arm regulation is simple, fast, perfect and safe. The **scraper blades** actively contribute to mixing, preventing material accumulation on the walls.

All blades can be made of **cast iron** or, upon request, **elastomer** with surface coating. Blade rotation and revolution speeds were designed to provide high productivity without creating material segregations with different specific sizes and weights.

**Material movement in the tanks is gentle, gradual and continuous.**

The graphic representation of a computerized technical analysis indicates how, after just one gear motor revolution, the blades fully cover the entire mixing tank surface in their movement.

## THE GEAR MOTOR

Specifically designed to equally distribute power to the various mixing parts, the gear motor rotates on an overdimensioned thrust bearing which, moving on the rollers, ensures silent operation without slips.

The kinematic chains are encased on a special steel container and all gears, made of 18NiCrMo5 cemented steel, are subject to heat treatments and hardening processes (tempering + air hardening) to obtain a high level of hardness that extends to the heart of the gear.

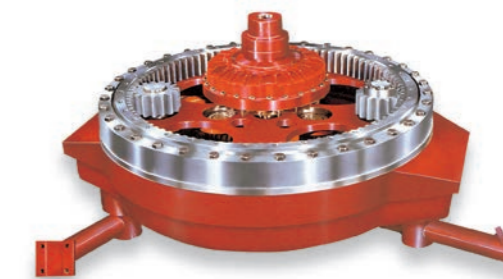

## HYDRO-DYNAMIC

The gears are oil bathed and constantly lubricated to guarantee maximum operating efficiency. Oil is continuously mixed from the bottom up by a specific blade and covers all parts as it falls. Oil is self-cooled thanks to the gaps in the gear motor and its level is kept low (from 4 to 10 cm) thanks to the ample gear motor container diameter. The gear motor bearings, particularly sturdy and long-lasting, are tested to guarantee maximum reliability in heavy-duty work cycles.



## WATER EMISSION

The machine is set to be equipped with almost any automatic water dosing system (by weight or volume).

Water is emitted by a series of adjustable nozzles that distribute water over the entire mix surface.

Recycle water is directly emitted by a blade sprayer using a timed dosing system (upon request).



## WASHING SYSTEM

This equipment is available in manual and automatic version. The washing system, used during the cycle phases, allows the mixing of concretes with different colours or mix designs avoiding the

contamination of the batches. The frequent use (several times a day) makes the cleaning process at the end of the working day easier and more efficient.

## DISCHARGE

The mixer discharges through a circular section door driven by an oil hydraulic cylinder. The door seal is made up of polyurethane gaskets. The door can be manually opened by a hydraulic pump in the event of emergency.

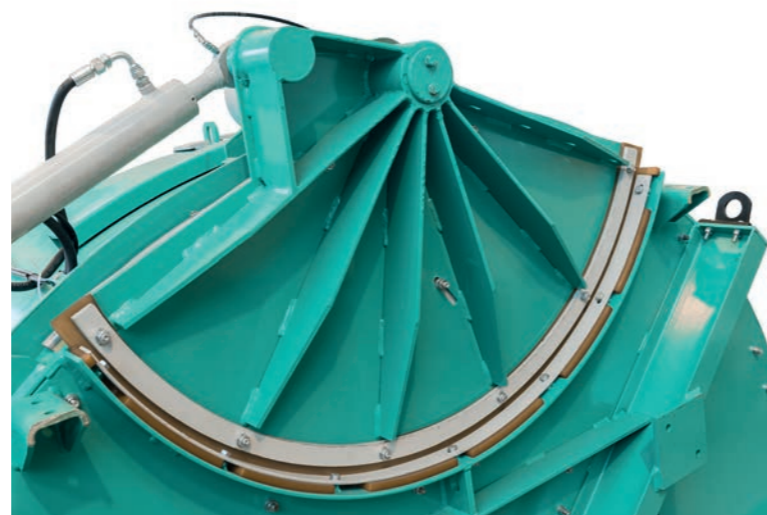

## CLEANING AND MAINTENANCE EASE

The wide opening angle on the covers permits easy access to the mixer interior. The lack of sharp corners and the rounded shape of the arms permit easy and fast cleaning.



## SAFETY SYSTEM WITH KEY CODE

Safe access door opening device.



## MOISTURE MIX PROBE

For automatic water dosing control.



## CONCRETE PICKING DEVICE

For laboratory tests and special products (optional).

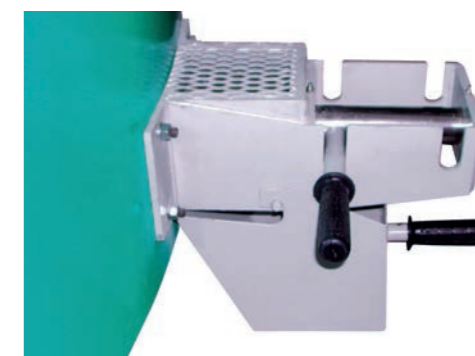



# ORUMD

## MIXING TANK

The mixing tank is expanded in relation to the amounts to be mixed to quickly obtain a high quality mix.

The mixing tank is made with **larger press-bent edges** to simultaneously provide the structure with sturdiness and elasticity.

The tank lining is made up of small bolted and interchangeable elements, made of **special wear-resistant steel**. Their rotation in the various positions significantly lengthens working life.

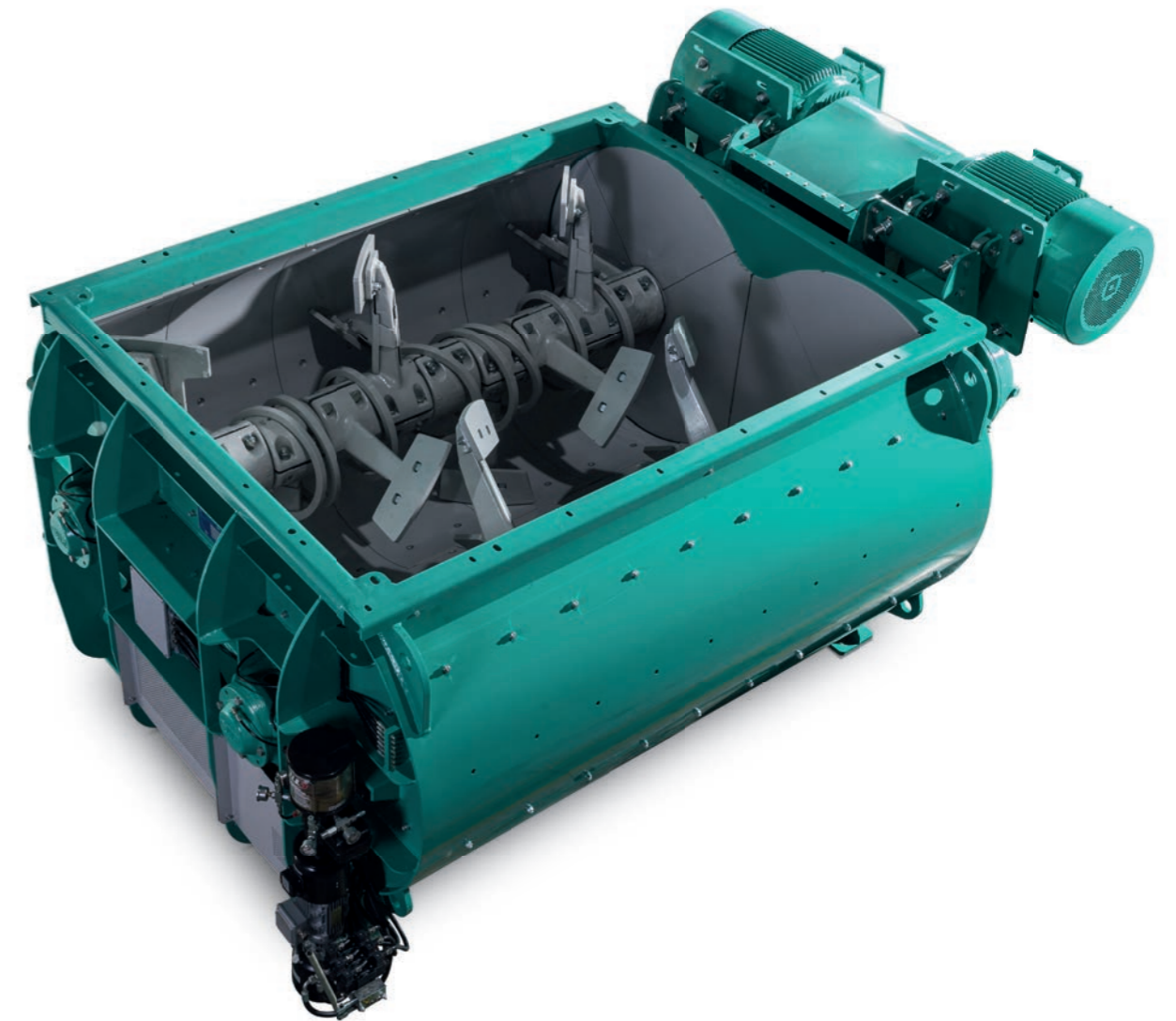

## SEALING SYSTEMS

The sealing systems installed on our machines' mixing axes are fully reliable.

The automatic and centralised lubrication system, equipped with 4 independent pumps, is highly efficient and its action, combined with our sealing system, significantly reduces maintenance.

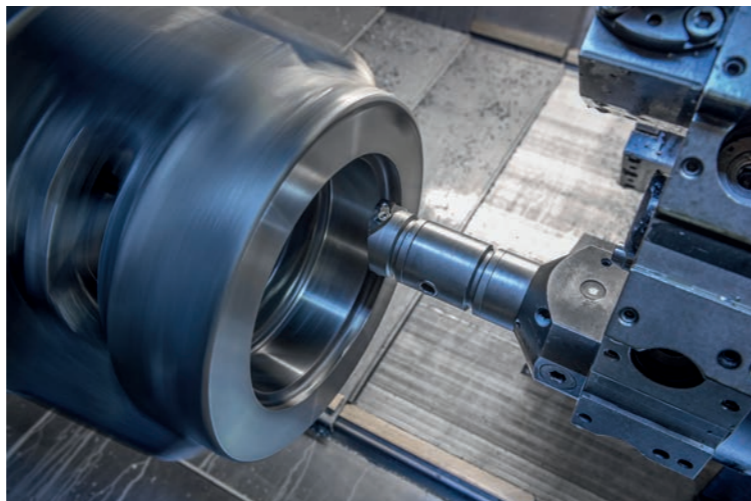

## MIXING BLADES AND ARMS

The **arms** are protected by easy-to-replace **wear-resistant plates** that help to improve mixing, thanks to the larger contact area, while they avoid arm wear during the pre-mixing process.

The blades, installed on the arms, are made of **anti-wear high-resistant steel** with a profile designed to **optimise performance** and reduce mixing time.

The **blade and arm tilt** causes the mix to move according to two counter-rotating propellers, partially overlapping, to obtain completely forced mixing, both horizontally and vertically.

**Any lightweight material centrifuge and floating separation phenomenon is excluded.**

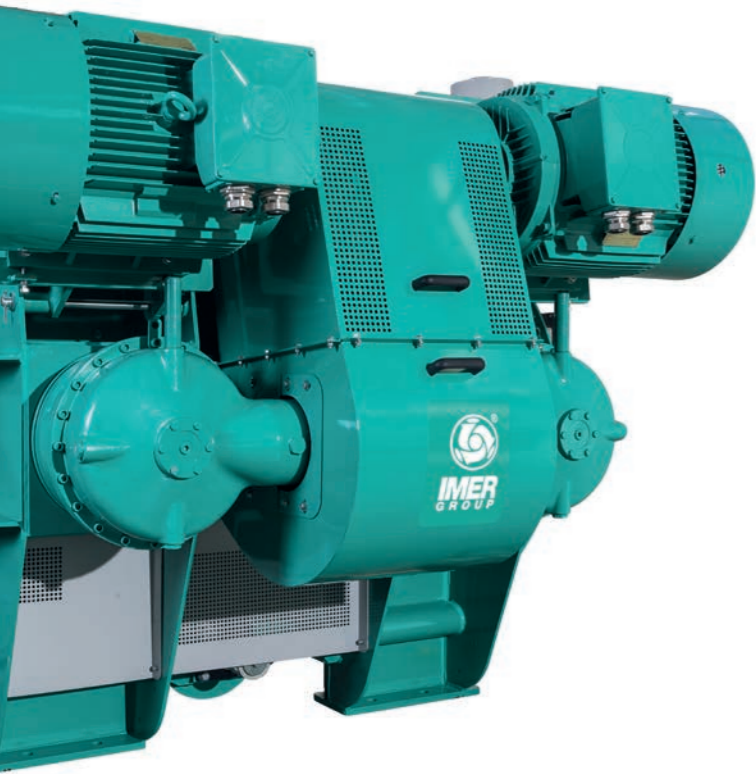

### GEAR MOTORS

Gear motors are equipped with an infeed pinion set with an expanded service factor to eliminate any possible overheating even in heavy-duty work conditions.

### DISCHARGE DOOR

The discharge door is equipped with interchangeable lining, adjustable contrast blades and a gasket system able to guarantee an excellent sealing even with very fluid mixes. The door extends over the entire length of the mixing tank and permits full and fast discharge. The door can be manually opened by a hydraulic pump in the event of emergency.



### OPENINGS AND INSPECTION DOORS

Inspections and maintenance are made easy by the large openings and doors with protection grates. All elements meet the most stringent international safety regulations.



### 4-PUMP LUBRICATION SYSTEM



### WATER SYSTEM

The system permits even water distribution over the entire surface, guaranteeing fast mix homogenisation.



## COMPLETE LIST OF ACCESSORIES FOR ORU MS MIXER

- AUTOMATIC HIGH PRESSURE MIXER CLEANING SYSTEMS
- AUTOMATIC MICROWAVE MOISTURE DETECTION SYSTEMS
- HOT WATER OR STEAM HEATING SYSTEMS
- COOLED WATER OR ICE COOLING SYSTEMS
- AGGREGATE/SKIP/CONVEYOR BACKUP HOPPER
- CONCRETE BACKUP HOPPER
- ADDITIVE SYSTEM BY WEIGHT, VOLUME OR TIMED
- LIQUID OR POWDER COLOUR DOSING SYSTEM
- DUST VACUUM AND RECOVERY SYSTEM
- UP TO TWO ADDITIONAL CIRCULAR SECTION DISCHARGE DOORS DRIVEN BY OIL HYDRAULIC CYLINDER WITH PARTIAL OR FULL OPENING
- AIRBAG
- CONCRETE SAMPLING DEVICE
- HARD SINTERED METAL BASES AND CASE

- MIXING BLADES WITH ELASTOMER OR VIDIA METAL SURFACE COATINGS
- METALLIC FIBRE DOSING SYSTEM
- PLASTIC FIBRE DOSING SYSTEM
- TEMPERATURE PROBES
- 1- OR 2-COMPARTMENT CEMENT SCALE



### Technical specifications

ORU MS RANGE		ORUMS 500/330	ORUMS 750/500	ORUMS 1200/800	ORUMS 1500/1000	ORUMS 2250/1500	ORUMS 2250/1500S	ORUMS 3000/2000
Load capacity	l	500	750	1200	1500	2250	2250	3000
Load capacity	kg	790	1200	1900	2400	3600	3600	4800
Soft yield	l	478	725	1160	1450	2175	2175	2900
Vibrated yield	l/kg	330	500	800	1000	1500	1500	2000
Mixing and discharge time	sec.	45	45	46	45	60	45	60
Stars and blades	n.	1x3	1x3	1x3	2x2	2x2	2x2	3x2
Scraper blades	n.	1	1	1	1	1	1	1
Tangent blades	n.	-	-	-	1	1	1	2
Differential case	r.p.m.	16	16	14.7	12.4	10.4	12.4	10.4
Star	r.p.m.	46	46	44.5	42	35.4	42	35.4
Mixing power	kW	15	18.5	30	45	55	75	110
Oil hydraulic unit power	kW	2.2	2.2	3	3	3	3	3
Weight	kg	1800	2000	3500	4800	5500	5600	8800
Whisk (r.p.m.)	r.p.m.	-	-	-	-	-	-	-

## COMPLETE LIST OF ACCESSORIES FOR ORU MD MIXER

- AUTOMATIC HIGH PRESSURE MIXER CLEANING SYSTEMS
- AUTOMATIC MICROWAVE MOISTURE DETECTION SYSTEMS
- HOT WATER OR STEAM HEATING SYSTEMS
- COOLED WATER OR ICE COOLING SYSTEMS
- AGGREGATE/SKIP/CONVEYOR BACKUP HOPPER
- CONCRETE BACKUP HOPPER
- ADDITIVE SYSTEM BY WEIGHT, VOLUME OR TIMED
- LIQUID OR POWDER COLOUR DOSING SYSTEM
- DUST VACUUM AND RECOVERY SYSTEM
- BLADES THICKENED WITH 500 HB OR HIGH-RESISTANT CHROME CAST IRON
- AIRBAG

- AUTOMATIC AND CENTRALISED LUBRICATION SYSTEM
- TEMPERED STEEL TANK LINING
- CLEANING RINGS
- SECOND DOOR INSTALLATION UPON REQUEST

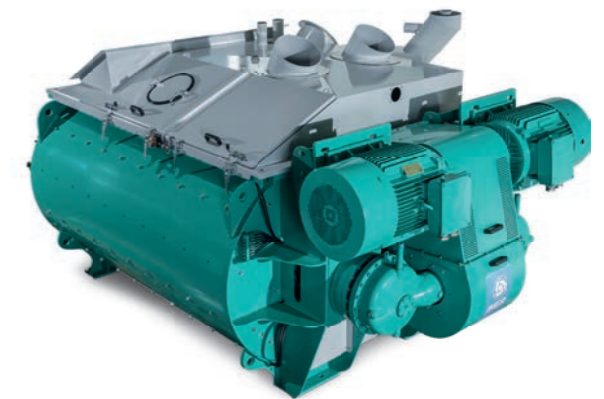

### Technical specifications

ORU MD RANGE		ORUMD 3000/2000	ORUMD 3750/2500	ORUMD 4500/3000	ORUMD 5000/3350	ORUMB 6000/4000	ORUMB 6750/4500
Load capacity	l	3000	3750	4500	5000	6000	6750
Load capacity	kg	4740	5930	7100	7900	9480	10600
Vibrated yield	l	2000	2500	3000	3350	4000	4500
Cycle time	sec.	55	60	65	70	75	80
Max aggregate size	mm	0-150	0-150	0-150	0-150	0-150	0-150
Mixing power	kW	2x37	2x45	2x55	2x65	2x75	2x90
Mixing blades	n.	12	16	20	20	16	16
Oil hydraulic unit	kW	1.5	1,5	1,5	1,5	-	-
Skip load capacity	l	3000	3750	4500	5000	6000	6750
Standard skip speed	m/min	35	35	37	37	24	24
Skip power	kW	30	37	45	55	55	65
Weight (without Skip)	kg	7100	8200	9300	9500	10800	11200

## MANAGEMENT SYSTEMS





# MANAGEMENT SYSTEMS

The IMER Group management units for the concrete batching plants are “user friendly” systems able to plan, control and automatically coordinate all the plant operations and to constantly check the production process. Our management systems are also available in touch version.



## MOISTURE MIX PROBE

The moisture mix probe installed on the bottom of the mixer measures and displays the percentage of moisture contained in the mix. A correct positioning contributes towards a correct measurement of moisture. To ensure a precise w/c ratio it is very important to interface the probes with an automation system able to accurately process the data. Thanks to the specific software for the microwave reading of the moisture probe, it is possible to achieve a high level of water metering accuracy.

## HPS 2100-V

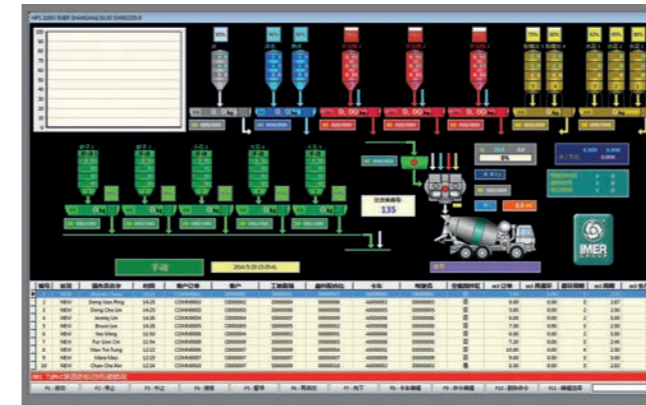

A customized software solution for the automation of the most advanced concrete production for the precast industry.

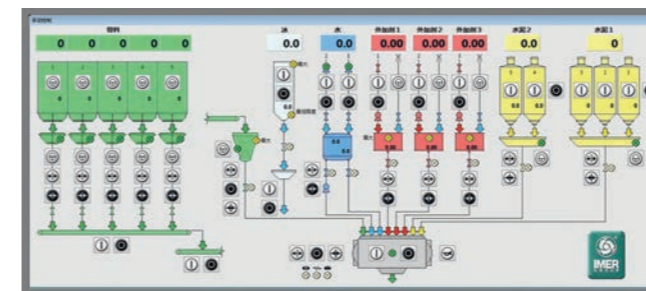

User-friendly interface. Extremely intuitive and simple to use.



HPS 2100-V is a customised and automated software solution for the most advanced concrete pre-packaging processes. Thanks to its user-friendly interface, the system is extremely simple to use. HPS 2100-V is the result of synergies between experience, technology and flexibility offered to the customer. The basic hardware configuration includes a personal computer with an LCD monitor as well as the peripheral devices needed to store and enter data. Microsoft Windows operating system is used, available in different languages. Real-time operation is ensured by the PLC.

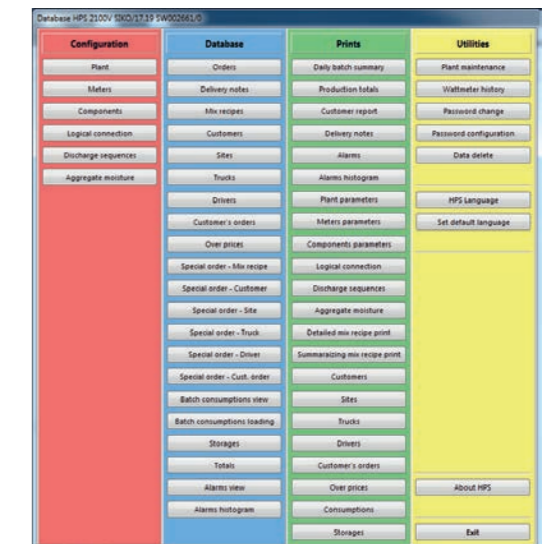

EPS-2100 is a control system aimed at automating batching plants with standard operation. Its versatile architecture is merely structured for the operational management of the concrete pre-packaging process. Thanks to its user-friendly interface, the system is extremely simple to use: the objective is to allow the operator to manage the entire mixing plant in a completely autonomous and safe manner. The basic configuration includes a management and monitoring system (PLC) with functional keyboard and LCD display, and application software available in different languages.

*Concept & design: Emporio ADV*

*© Copyright by Le Officine Riunite - Udine S.p.A. 2017*



Le Officine Riunite - Udine S.p.A. Concrete Machinery Division  
Via Santa Caterina, 35  
33030 Basaldella di Campofornido (UD) | Italy  
t + 39 0432 563911 | f +39 0432 562131  
oru@oru.it | www.oru.it



Le Officine riunite\_Udine S.p.A. reserve the right to change the information contained herein without prior notice when they consider it justified. The data and dimensions are therefore not to be considered as binding. The illustrations may include accessories and therefore they could be slightly different from the standard versions of the equipment.